

**Lavavajillas
Lavevaisselle
Dishwasher
Geschirrspüler
Lavastoviglie**

Modelos:

FI-30

Junio 2003 June

FAGOR 

Fagor Industrial

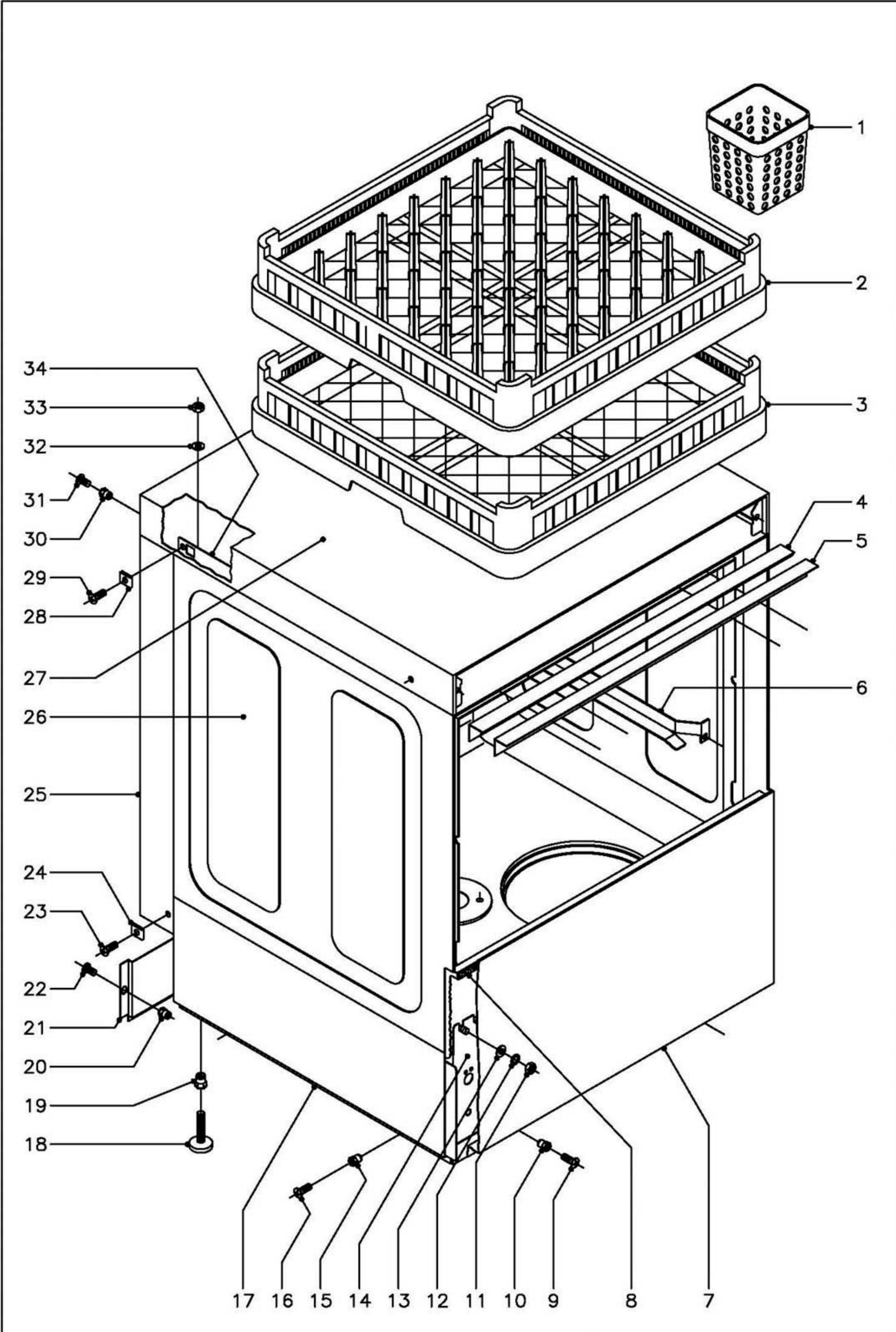

N plano C-1366	Firma 	Fecha 6-2003	Aparato MUEBLE LAVAVAJILLAS FI-30	Lamina 1	Fagor Industrial S.Coop. FAGOR Oñate
-------------------	--	-----------------	---	-------------	--

MOD.

LAVAVAJILLAS FRONTAL

ZONA

MUEBLE

PLANO

C-1366

ITEM	CODIGO	DENOMINACION	TEXTO	FI-30															NOTAS
1	Z655314	Cestillo cubiertos		1															
2	Z655302	Cestillo platos CP-16/18		1															
3	Z655301	Cestillo base CT-10		1															
4	Z200315	Perfil caja		1															
5	Z200309	Escuadra sujecion perfil		1															
6	Z200305	Guia cestillo derecha		1															
s/n	Z200306	Guia cestillo izquierda		1															
	Q232040	Arandela plana A-6		4															
	Q162040	Tuerca exagonal M-6		4															
7	Z202913	Panel frontal		1															
8	Z200313	Perfil goma esponjosa		1															
9	Q152004	Tornillo aplastado M-5x13		2															
10	Q221342	Remache exagonal M-5		2															
11	Q162040	Tuerca exagonal M-6		8															
12	Q262040	Arandela muelle A-6		8															
13	Q232040	Arandela plana A-6		8															
14	Z200101	Armazon completo		1															
15	Q221342	Remache exagonal M-5		4															
16	Q152004	Tornillo aplastado M-5x13		4															
17	Z202903	Panel lateral izquierdo		1															
s/n	Z202902	Panel lateral derecho		1															
18	Z200105	Pata regulable		4															
19	Q221345	Remache exagonal M-10		4															
20	Q221342	Remache exagonal M-5		2															
21	Z202912	Panel posterior inferior		1															
22	Q152004	Tornillo aplastado M-5x13		2															
23	Q152004	Tornillo aplastado M-5x13		2															
24	Q221012	Tuerca rapida M-5		2															
25	Z202904	Panel posterior		1															

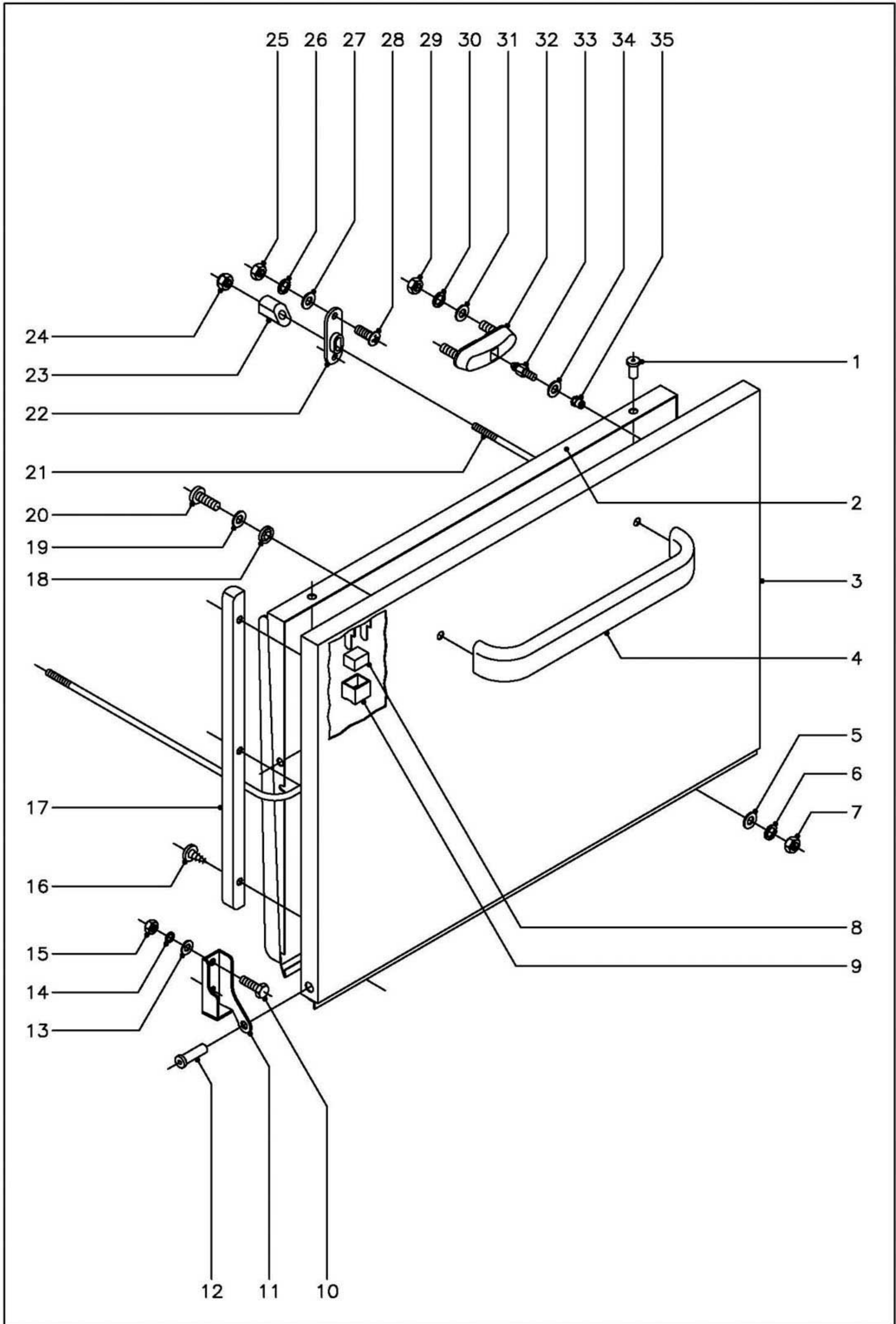

N plano C-1367	Firma 	Fecha 6-2003	Aparato PUERTA LAVAVAJILLAS FI-30	Lamina 2	Fager Industrial S.Coop. FAGOR  Orote
-------------------	--	-----------------	---	-------------	--

MOD.

LAVAVAJILLAS FRONTAL

ZONA

PUERTA

PLANO

C-1367

ITEM	CODIGO	DENOMINACION	TEXTO	FI-30																NOTAS
1	Q412000	Remache tubular Ø4x8		4																
2	Z200545	Contrapuerta soldada		1																
3	Z200541	Puerta soldada		1																
4	Z200512	Asa puerta		1																
5	Q232030	Arandela plana A-5		2																
6	Q262030	Arandela muelle A-5		2																
7	Q162030	Tuerca exagonal M-5		2																
8	Z200506	Iman		1																
9	Z200507	Protector iman		1																
10	Q012042	Tornillo exagonal M-6x15		4																
11	Z400514	Bisagra izquierda		1																
s/n	Z400515	Bisagra derecha		1																
12	Z400516	Eje puerta		2																
13	Q232040	Arandela plana A-6		4																
14	Q262040	Arandela muelle A-6		4																
15	Q162040	Tuerca exagonal M-6		4																
16	Q082005	Tornillo chapa 4,2x13		6																
17	Z200524	Marco puerta		2																
18	Q308002	Arandela dubo A-6		2																
19	Q232040	Arandela plana A-6		2																
20	Q032041	Tornillo alomado M-6x10		2																
21	Z200521	Varilla tensor		1																
22	Z200310	Soporte tensor		2																
23	Z200522	Tensor de puerta		2																
24	Q222012	Tuerca autoblocante M-6		2																
25	Q162030	Tuerca exagonal M-5		4																
26	Q262030	Arandela muelle A-5		4																
27	Q232030	Arandela plana A-5		4																
28	Q152004	Tornillo aplastado M-5x13		4																

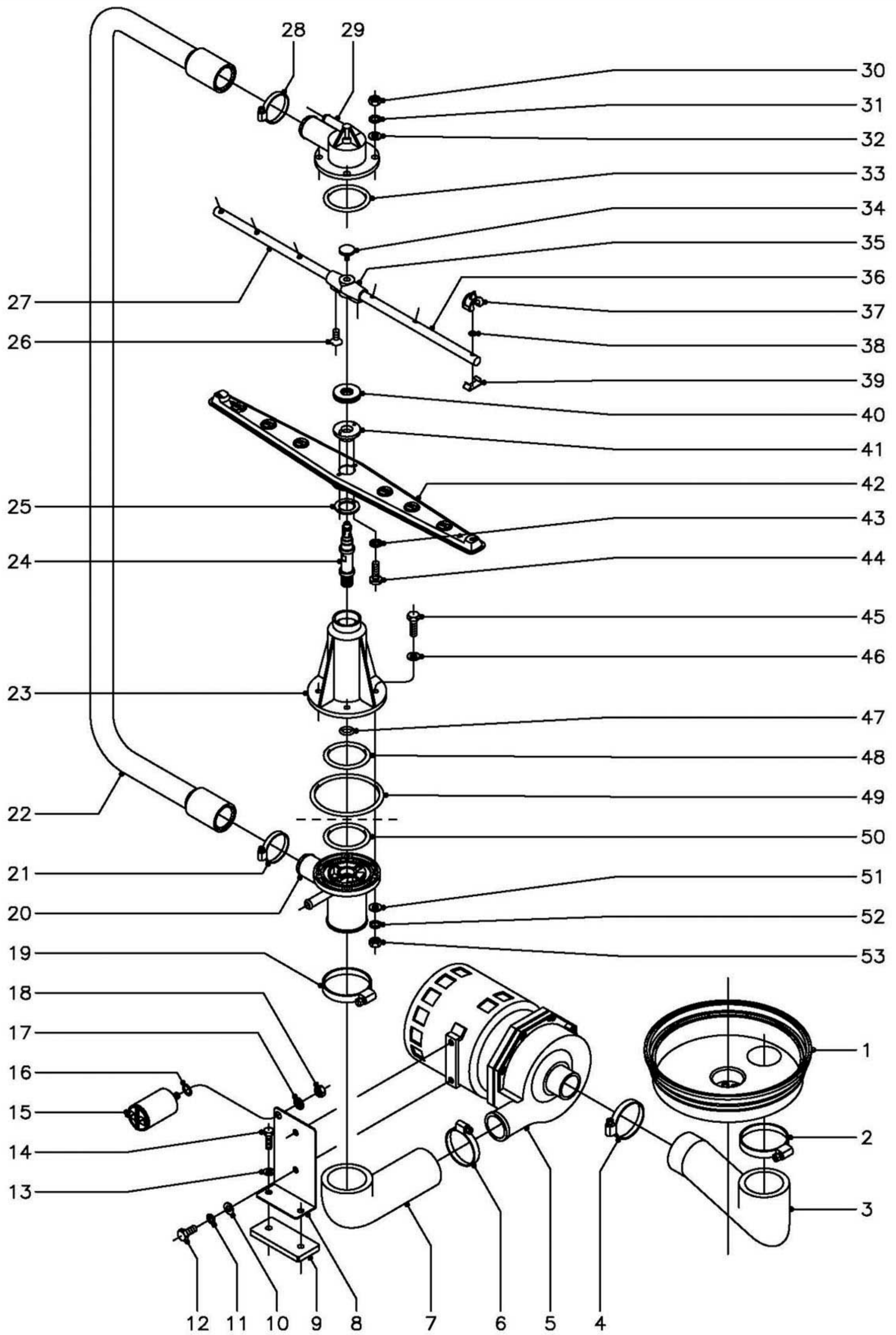

N plano
C-1368

Firma

Fecha
6-2003

Aparato
PARTE FUNCIONAL DE LAVADO
LAVAVAJILLAS FI-30

Lamina
3

Fagor Industrial S.Coop. **FAGOR**
Ofate

MOD.

LAVAVAJILLAS FRONTAL

ZONA

PARTE FUNCIONAL DE LAVADO

PLANO

C-1368

ITEM	CODIGO	DENOMINACION	TEXTO	FI-30														NOTAS
1	Z200906	Cubeta		1														
2	Q881324	Abrazadera 50 - 70		1														
3	Z200904	Codo aspiracion		1														
4	Q881307	Abrazadera 40 - 60		1														
5	Z201011	Bomba de lavado (230 V., 50Hz.)		1														
5	Z203511	Bomba de lavado (230 V., 60Hz.)		1														
	Z201081	Conjunto junta y reten de bomba		1														
	Z201082	Turbina 50 Hz. (Ø88mm.)		1														
	Z203571	Turbina 60 Hz. (Ø77mm.)		1														
6	Q881307	Abrazadera 40 - 60		1														
7	Z200905	Codo impulsion		1														
8	Z201002	Soporte motobomba		1														
9	Z201003	Base bomba lavado		1														
10	Q232040	Arandela plana A-6		2														
11	Q262040	Arandela muelle A-6		2														
12	Q012041	Tornillo exagonal M-6x10		2														
13	Q232030	Arandela plana A-5		2														
14	Q012033	Tornillo exagonal M-5x20		2														
15	V321300	Condensador 10 mF.		1														
16	Q307048	Junta torica Ø16,18xØ9,12xØ3,53		1														
17	Q242050	Arandela abanico A-8		1														
18	Q162050	Tuerca exagonal M-8		1														
19	Q881324	Abrazadera 50 - 70		1														
20	Z200703	Pasamuros		1														
21	Q881305	Abrazadera 25 - 40		1														
22	Z200706	Arbol de lavado		1														
23	Z200701	Soporte distribuidor inferior		1														
24	Z200704	Eje central		2														
25	Z650711	Amarre enganche distribuidor		2														

MOD.

LAVAVAJILLAS FRONTAL

ZONA

PARTE FUNCIONAL DE LAVADO

PLANO

C-1368

ITEM	CODIGO	DENOMINACION	TEXTO	FI-30										NOTAS
26	Q152024	Tornillo avellanado M-4x8		4										
27	Z201902	Rama aclarado izquierda		2										
28	Q881305	Abrazadera 25 - 40		1										
29	Z200707	Soporte distribuidor superior		1										
30	Q162040	Tuerca exagonal M-6		4										
31	Q262040	Arandela muelle A-6		4										
32	Q232040	Arandela plana A-6		4										
33	Q307052	Junta torica Ø60,83xØ50,17xØ5,33		1										
34	Q152016	Tornillo especial M-5x0,8		2										
35	Z201903	Soporte ramas aclarado		2										
36	Z201901	Rama aclarado derecha		2										
37	Z201905	Tobera aclarado		12										
38	Q307036	Junta torica Ø5,28xØ8,84xØ1,78		12										
39	Z201906	Enganche tobera aclarado		12										
40	Z200705	Tuerca especial M-14x1		2										
41	Z650704	Enganche distribuidor		2										
42	Z650716	Distribuidor montado		2										
43	Q242010	Arandela abanico A-3		4										
44	Q152015	Tornillo alomado M-3x6		4										
45	Q012046	Tornillo exagonal M-6x40		4										
46	Q306050	Arandela fibra roja Ø11xØ6,2x1,5		4										
47	Q307050	Junta torica Ø19,18xØ13,94xØ2,62		1										
48	Q307052	Junta torica Ø60,83xØ50,17xØ5,33		1										
49	Q307049	Junta torica Ø95,75xØ85,09xØ5,33		1										
50	Q307052	Junta torica Ø60,83xØ50,17xØ5,33		1										
51	Q232040	Arandela plana A-6		4										
52	Q262040	Arandela muelle A-6		4										
53	Q162040	Tuerca exagonal M-6		4										

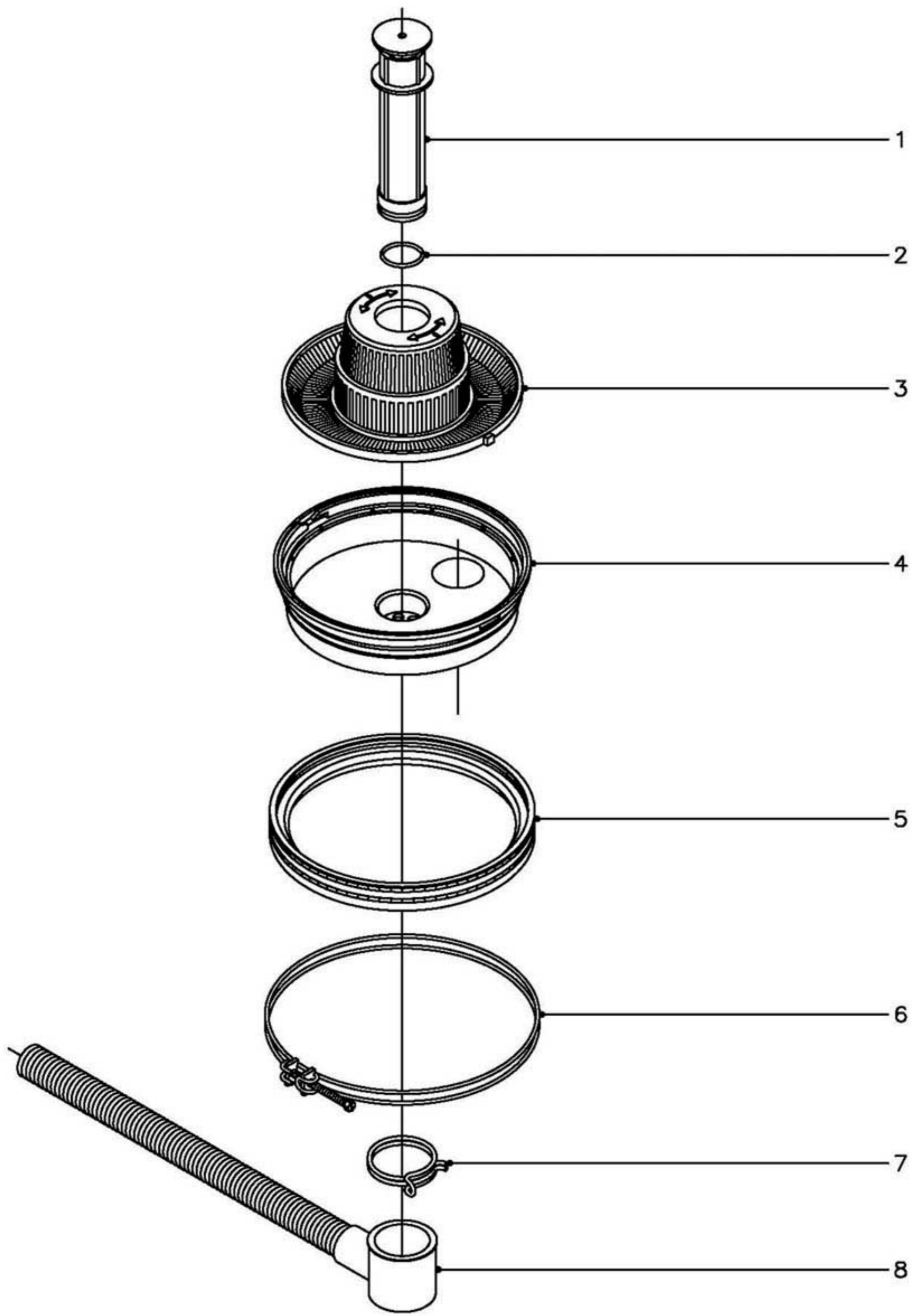

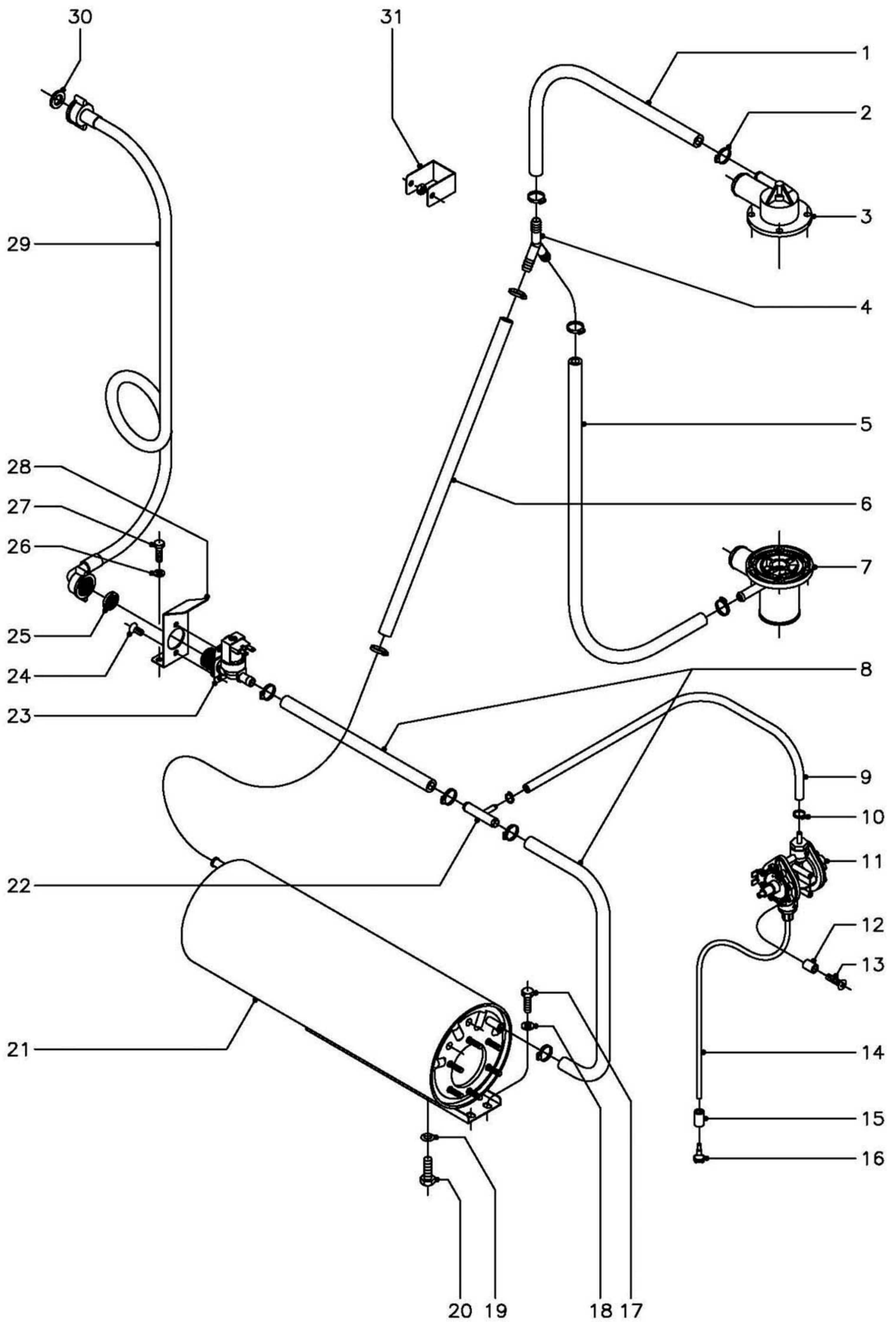

N plano
C-1370

Firma

Fecha
6-2003

Aparato

PARTE FUNCIONAL ACLARADO
LAVAVAJILLAS FI-30

Lamina
5

Fagor Industrial S.Coop. **FAGOR**
Ofite

MOD.

LAVAVAJILLAS FRONTAL

ZONA

PARTE FUNCIONAL ACLARADO

PLANO

C-1370

ITEM	CODIGO	DENOMINACION	TEXTO	FI-30																NOTAS
1	3676900	Tubo goma negra Ø17xØ10x360		1																
2	Q881302	Abrazadera 12 - 20		10																
3	Z200707	Soporte distribuidor superior		1																
4	Z201106	Racord en "Y"		1																
5	3676900	Tubo goma negra Ø17xØ10x780		1																
6	3676900	Tubo goma negra Ø17xØ10x580		1																
7	Z200703	Pasamuros		1																
8	3676900	Tubo goma negra Ø17xØ10x80		2																
9	3704000	Tubo goma negra Ø10,5xØ5x620		1																
10	Q881308	Abrazadera 8 - 14		2																
11	Z651123	Dosificador tensoactivo		1																
12	Z203007	Casquillo		2																
13	Q041324	Tornillo avellanado M-4x25		2																
14	3699200	Conducto tensoactivo Ø6xØ4x650		1																
15	Z701152	Peso filtro		1																
16	Z601153	Filtro aspiracion tensoactivo		1																
17	Q012031	Tornillo exagonal M-5x10		2																
18	Q232030	Arandela plana A-5		2																
19	Q307048	Junta torica Ø16,18xØ9,12xØ3,53		1																
20	Q012063	Tornillo exagonal M-10x20		1																
21	Z201710	Cuerpo calderin		1																
22	Z601157	Toma presion		1																
23	Z701135	Electrovalvula entrada de agua		1																
24	Q152024	Tornillo avellanado M-4x8		2																
25	Z701132	Filtro junta		1																
26	Q232030	Arandela plana A-5		2																
27	Q012031	Tornillo exagonal M-5x10		2																
28	Z201101	Escuadra amarre electrovalvula		1																
29	Z602121	Manguera entrada de agua		1																

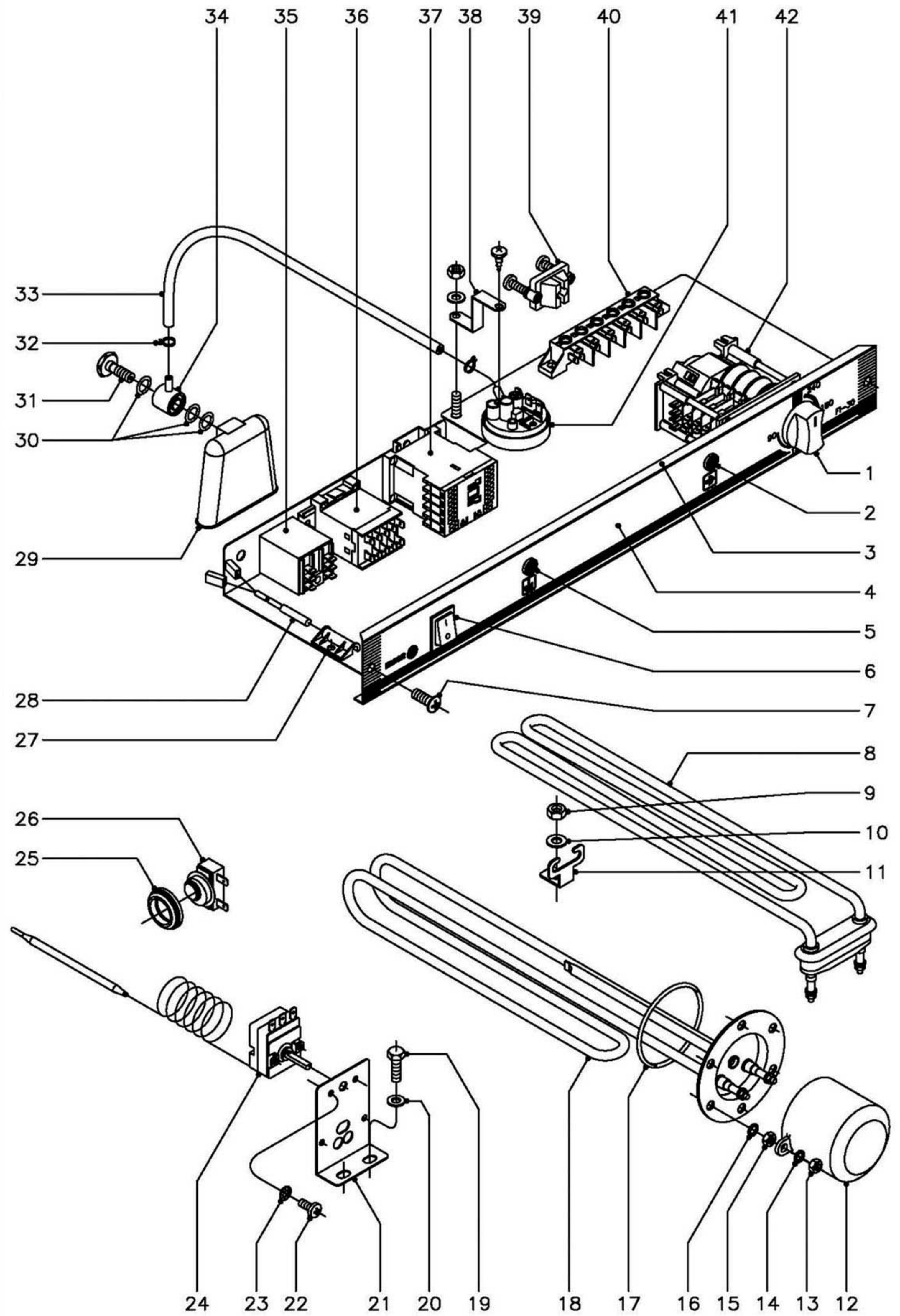

N plano
C-1371

Firma

Fecha
6-2003

Aparato

PARTE FUNCIONAL ELECTRICA
LAVAVAJILLAS FI-30

Lamina

6

Fagor Industrial S.Coop. **FAGOR**
Oñate

MOD.

LAVAVAJILLAS FRONTAL

ZONA

PARTE FUNCIONAL ELECTRICA

PLANO

C-1371

ITEM	CODIGO	DENOMINACION	TEXTO	FI-30															NOTAS
1	R663062	Boton de mando completo		1															
2	R693056	Piloto ambar		1															
3	Z202907	Frente extraible		1															
4	Z202909	Embellecedor adhesivo		1															
5	R693055	Piloto verde		1															
6	Z203033	Interruptor general		1															
7	Q152004	Tornillo aplastado M-5x13		2															
8	Z203601	Resistencia tanque 2800 W. 230V.		1															
9	Q162040	Tuerca exagonal M-6		1															
10	Q232040	Arandela plana A-6		1															
11	Z603602	Soporte resistencia tanque		1															
12	Z651731	Caperuza resistencia calderin		1															
13	Q163140	Tuerca exagonal M-6		2															
14	Q262040	Arandela muelle A-6		2															
15	Q163140	Tuerca exagonal M-6		6															
16	Q262040	Arandela muelle A-6		6															
17	Q307035	Junta torica AN-36		1															
18	Z201706	Resistencia calderin 2800 W.230V.		1															
19	Q012031	Tornillo exagonal M-5x10		2															
20	Q232030	Arandela plana A-5		2															
21	Z203047	Soporte termostatos		1															
22	Q153111	Tornillo alomado M-4x8		2															
23	Q242020	Arandela abanico A-4		2															
24	Z203014	Termostato calderin		1															
25	N503017	Soporte termostato		1															
26	Z718405	Termostato doble (tanque)		1															
27	Z203010	Amarre interruptor magnetico		1															
28	Z203009	Interruptor magnetico		1															
29	Z203011	Camara presostato		1															

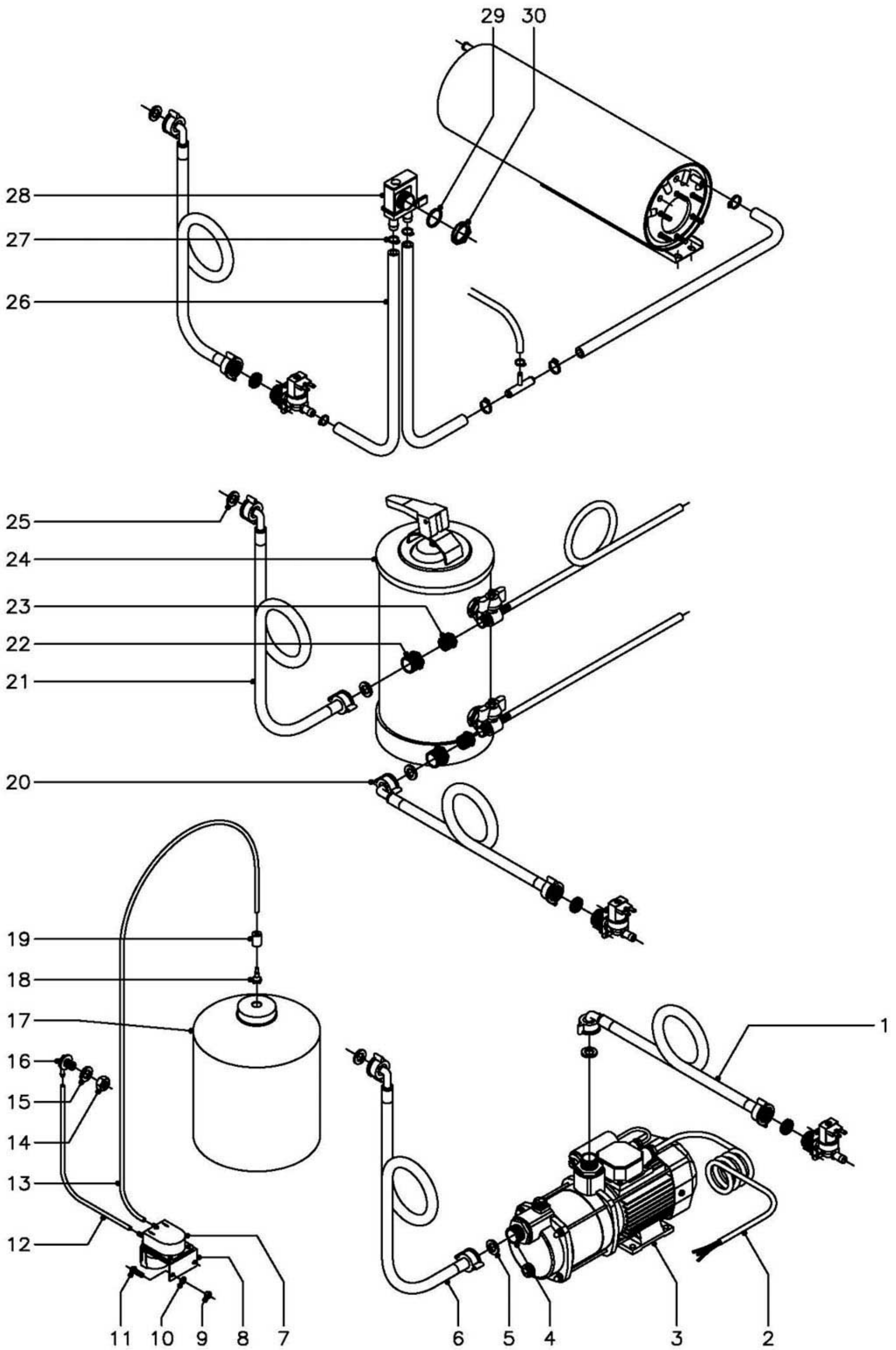

ITEM	CODIGO	DENOMINACION	TEXTO	FI-30															NOTAS
1210305187 KIT BOMBA PRESION																			
1	-	Manguera de maquina		-															
2	Z209510	Cableado bomba de presion		1															
3	Z209508	Bomba de presion (230 V., 50 Hz.)		1															
3	Z209508	Bomba de presion (230 V., 60 Hz.)		1															
4	Z209509	Manguito		2															
5	Q307031	Junta manguera entrada agua		2															
6	Z602121	Manguera entrada de agua		1															
1210305188 KIT DOSIFICADOR DETERGENTE																			
7	Z209521	Dosificador de detergente		1															
	Q082005	Tornillo chapa 4,2x13		2															
8	Z209518	Soporte dosificador de detergente		1															
9	Q162030	Tuerca exagonal M-5		2															
10	Q232030	Arandela plana A-5		2															
11	Q012031	Tornillo exagonal M-5x10		2															
12	3699200	Conducto detergente Ø6xØ4x500		1															
13	3699200	Conducto detergente Ø6xØ4x2000		1															
14	Q162070	Tuerca exagonal M-12		1															
15	Q307031	Arandela junta Ø24xØ14x3		1															
16	Z230902	Pasamuros detergente		1															
17	-	Garrafa detergente		-															
18	Z601153	Filtro aspiracion		1															
19	Z701152	Peso filtro		1															

ITEM	CODIGO	DENOMINACION	TEXTO	FI-30														NOTAS
1210305191 KIT DESCALCIFICADOR 8l.																		
20	-	Manguera de maquina		-														
21	Z602121	Manguera entrada de agua		1														
22	Z209515	Tuerca reduccion 3/4" - 1/2"		2														
23	Z209516	Tuerca reduccion 1/2" - 3/8"		2														
24	Z209511	Descalcificador 8l.		1														
25	Q307031	Junta manguera entrada agua		2														
1210305186 KIT DESCALCIFICADOR 12l.																		
20	-	Manguera de maquina		-														
21	Z602121	Manguera entrada de agua		1														
22	Z209515	Tuerca reduccion 3/4" - 1/2"		2														
23	Z209516	Tuerca reduccion 1/2" - 3/8"		2														
24	Z209507	Descalcificador 12l.		1														
25	Q307031	Junta manguera entrada agua		2														
1210305192 KIT DESCALCIFICADOR 16l.																		
20	-	Manguera de maquina		-														
21	Z602121	Manguera entrada de agua		1														
22	Z209515	Tuerca reduccion 3/4" - 1/2"		2														
23	Z209516	Tuerca reduccion 1/2" - 3/8"		2														
24	Z209512	Descalcificador 16l.		1														
25	Q307031	Junta manguera entrada agua		2														

MOD.

LAVAVAJILLAS FRONTAL

ZONA

VARIOS

PLANO

ITEM

CODIGO

DENOMINACION

TEXTO

FI-30

NOTAS

Z206131 Folleto de instrucciones

1

Z203032 Esquema electrico adhesivo

1

(Plano HC-16498-3)

Z203051 Esquema electrico de montaje

1

(Plano HC-17262-1)

Z603041 Cable de alimentacion

1

Z203025 Instalacion electrica

1

MOD.		LAVAVAJILLAS FRONTAL AZKOYEN		ZONA	PIEZAS ESPECIFICAS (AZKOYEN)							PLANO
ITEM	CODIGO	DENOMINACION	TEXTO	A-320-B (FI-30)								NOTAS
	Z228812	Panel frontal B Azkoyen		1								
	Z228813	Adhesivo panel B		1								
	Z448616	Pegatina toma detergente		1								
	Z230902	Pasamuros detergente		1								
	Z448613	Cable dosificador Azkoyen		1								
	Z448614	Conducto aspiracion c/filtro Azkoyen		1								
	Z208801	Frente extraible		1								
	Z208802	Embellecedor adhesivo		1								
	R693056	Piloto ambar		1								
	Z223001	Conmutador de funciones		1								
	Z203007	Casquillo		2								
	Q041324	Tornillo avellanado M-4x25		2								
	Z223005	Presostato simple		1								
	Z103077	Racord en "Y" presostatos		1								
	Z658813	Boton de mando con anillo comp.		1								
	Z658607	Indicador de mando		1								
	Z658602	Asa puerta		1								
	Z208603	Adhesivo puerta		1								
	Z208608	Libro de instrucciones		1								
	Z208610	Hoja garantia Azkoyen		1								
	Z658609	Palet Azkoyen		1								
	Z220901	Bomba de desagüe		1								
	Z220904	Soporte bomba de desagüe		1								
	Q012031	Tornillo exagonal M-5x10		4								
	Q242030	Arandela abanico A-5		4								
	Q232030	Arandela plana A-5		4								
	Z220902	Acumulador		1								
	Z220903	Manguera de desagüe		1								
	Q881305	Abrazadera 25 - 40		2								

MOD.

LAVAVAJILLAS FRONTAL FUTURMAT

ZONA

PIEZAS ESPECIFICAS (FUTURMAT)

PLANO

ITEM

CODIGO

DENOMINACION

TEXTO

FV34C
(FI-30)

NOTAS

Z204501 Embellecedor adhesivo

1

Z204504 Boton de mando con anillo compr.

1

Z604505 Indicador de mando

1

Z200539 Asa puerta

1

Q012042 Tornillo exagonal M-6x15

2

Q162040 Tuerca exagonal M-6

2

MOD.

LAVAVAJILLAS FRONTAL RESTOMAT

ZONA

PIEZAS ESPECIFICAS (RESTOMAT)

PLANO

ITEM

CODIGO

DENOMINACION

TEXTO

KM-30
(FI-30)

NOTAS

Z204911

Embellecedor adhesivo

1

Z214902

Boton de mando con anillo compr.

1

Z650531

Asa puerta

1

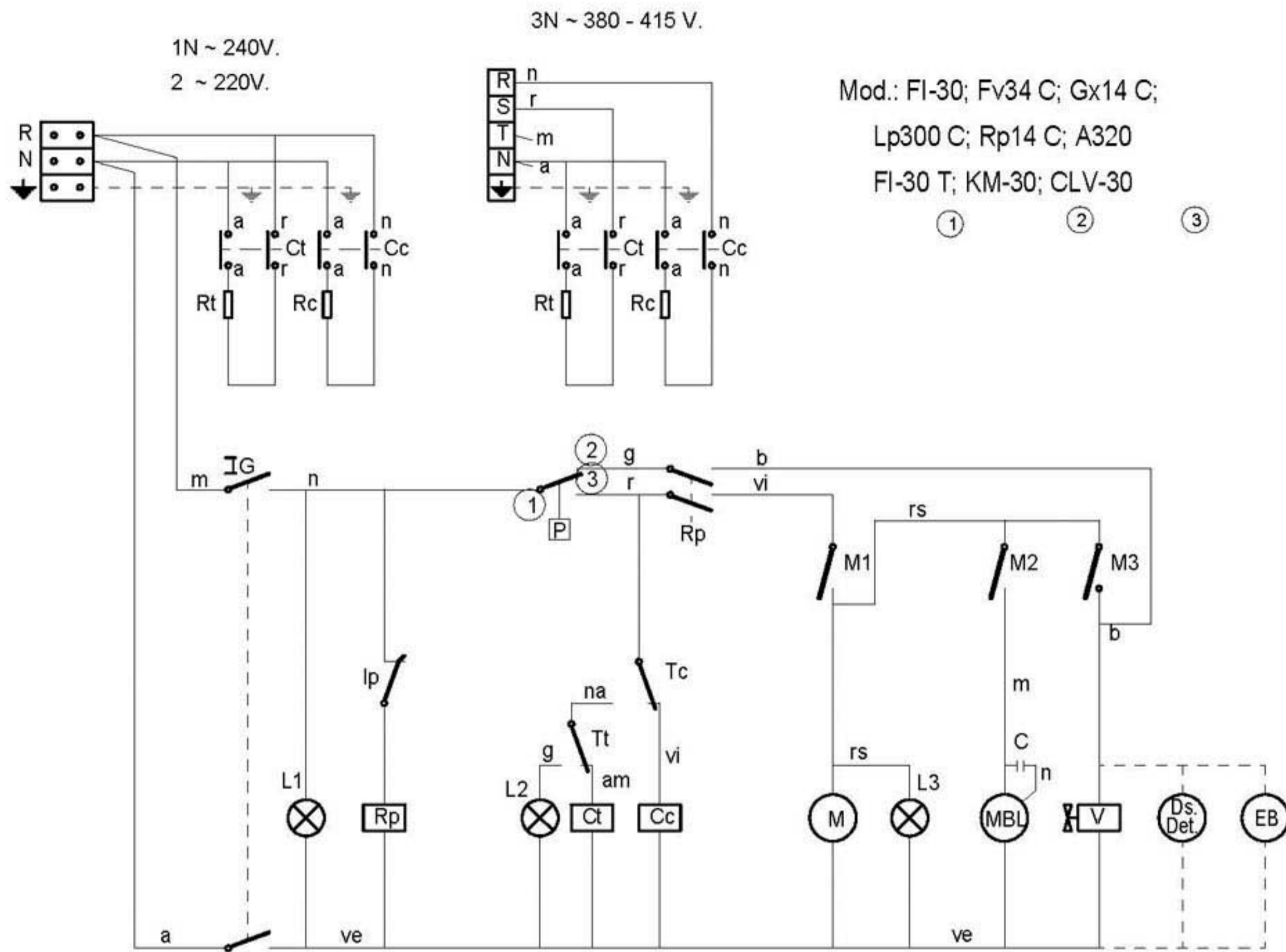

Mod.: FI-30; Fv34 C; Gx14 C;
 Lp300 C; Rp14 C; A320
 FI-30 T; KM-30; CLV-30

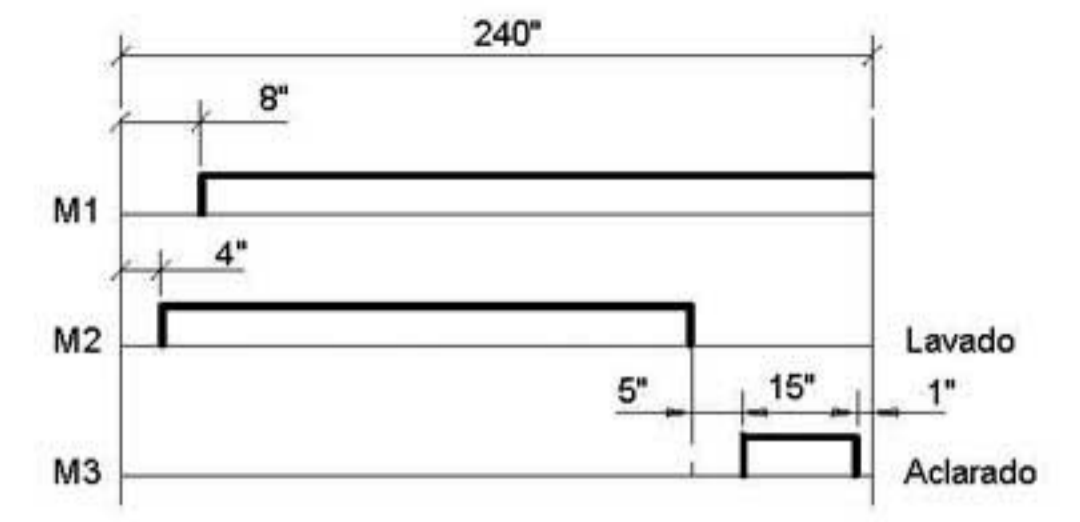

CODIGO DE COLORES:
 r = rojo-red-rouge
 m = marron-brown-marron
 g = gris-grey-gris
 n = negro-black-noir
 a = azul-blue-bleu
 b = blanco-white-blanc
 vi = violeta-violette-violet
 am = amarillo-yellow-jaune
 na = naranja-orange-orange
 rs = rosa-rose-pink
 ve = verde-green-vert
 am/ve = amarillo verde-yellow green-jaune vert

IG = Interruptor General
 L1 = Lampara de marcha
 Ip = Micro de puerta
 Rp = Relé puerta
 P = Presostato
 Tc = Termostato calderin
 Tt = Termostato tanque
 Cc = Contactor calderin
 Ct = Contactor tanque
 L2 = Lampara máquina preparada
 Rc = Resistencia calderin
 Ds Det = Dosificador detergente (opcional)

Rt = Resistencia tanque
 M = Motor programador
 M1 = Micro programador marcha
 M2 = Micro programador lavado
 M3 = Micro programador aclarado
 L3 = Lámpara de ciclo
 MBL = Motobomba lavado
 C = Condensador de motobomba
 V = Válvula de llenado y aclarado
 EB = Electrobomba de presión (opcional)

Esquema teorico adhesivo		Papel adhesivo	Z-203032	
Nº	Pieza	Cant.	Material	Nº Clasificacion
Nº	Modificacion		Propuesta de	Fecha
①	Introducir denominación FI-30 T		Palacio	20-4-98
②	Introducir denominación KM - 30		J.M.P.	22-7-99
③	Introducir modelo CORECO		Palacio	28-1-00
Dibujado		Firma	Fecha	 Fagor Industrial, Koop Elk, Mugatua
Proyectado		S. N.	27-9-95	
Comprobado				
Escala				
LAVAVAJILLAS				Mecanizado superficial
				Plano numero HC-16498 -3
				Sustituye al N°
				Sustituido por:

Plano hau ez dateke erabil ez berizta gure baimentz gabe

1N ~ 240V.
2 ~ 220V.

3N ~ 380 - 415 V.

Mod.: A 320 B

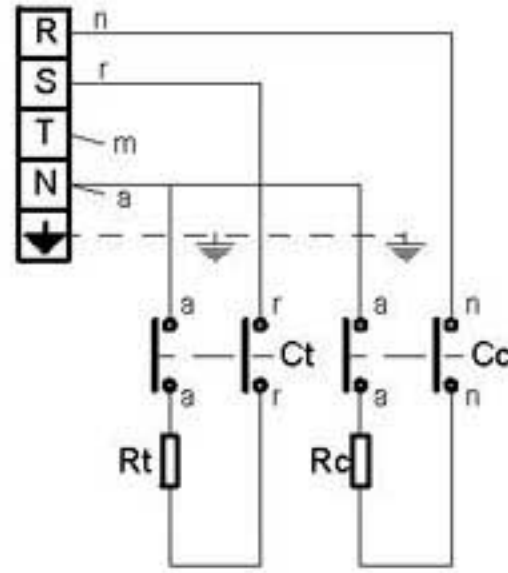
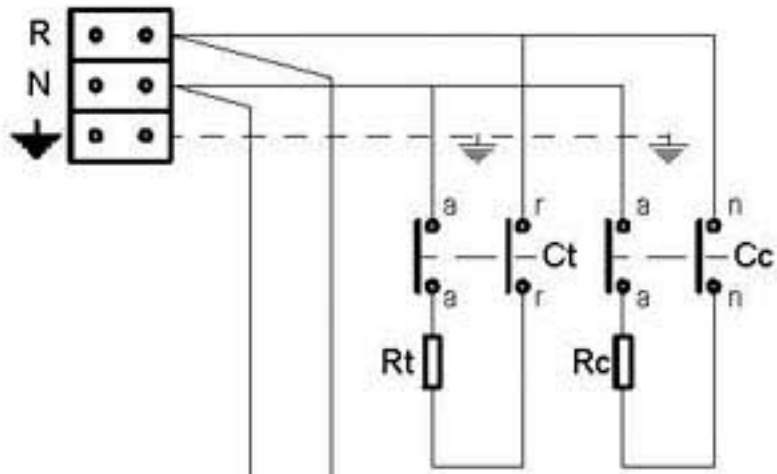

	1 - 2 1a 2a	3 3a	4 4a	5 - 6 5a 6a	7 7a	8 8a
		X	X	X		X
0						
	X		X	X	X	X

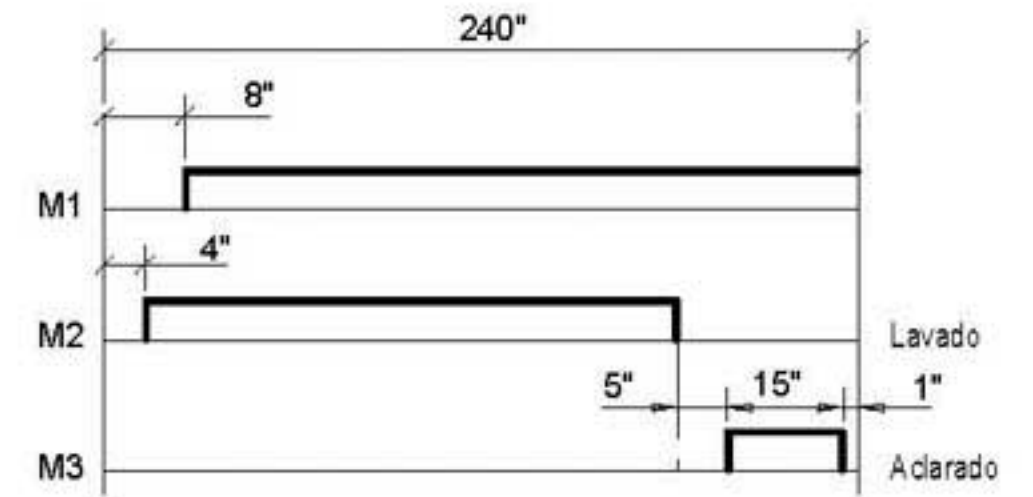
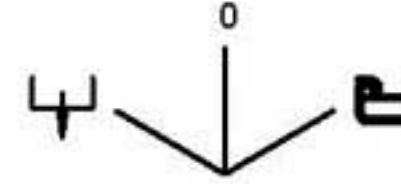

CODIGO DE COLORES:

- r = rojo-red-rouge
- m = marron-brown-marron
- g = gris-grey-gris
- n = negro-black-noir
- a = azul-blue-bleu
- b = blanco-white-blanc
- vi = violeta-violette-violet
- am = amarillo-yellow-jaune
- na = naranja-orange-orange
- rs = rosa-rose-pink
- ve = verde-green-vert
- am/ve = amarillo verde-yellow green-jaune vert

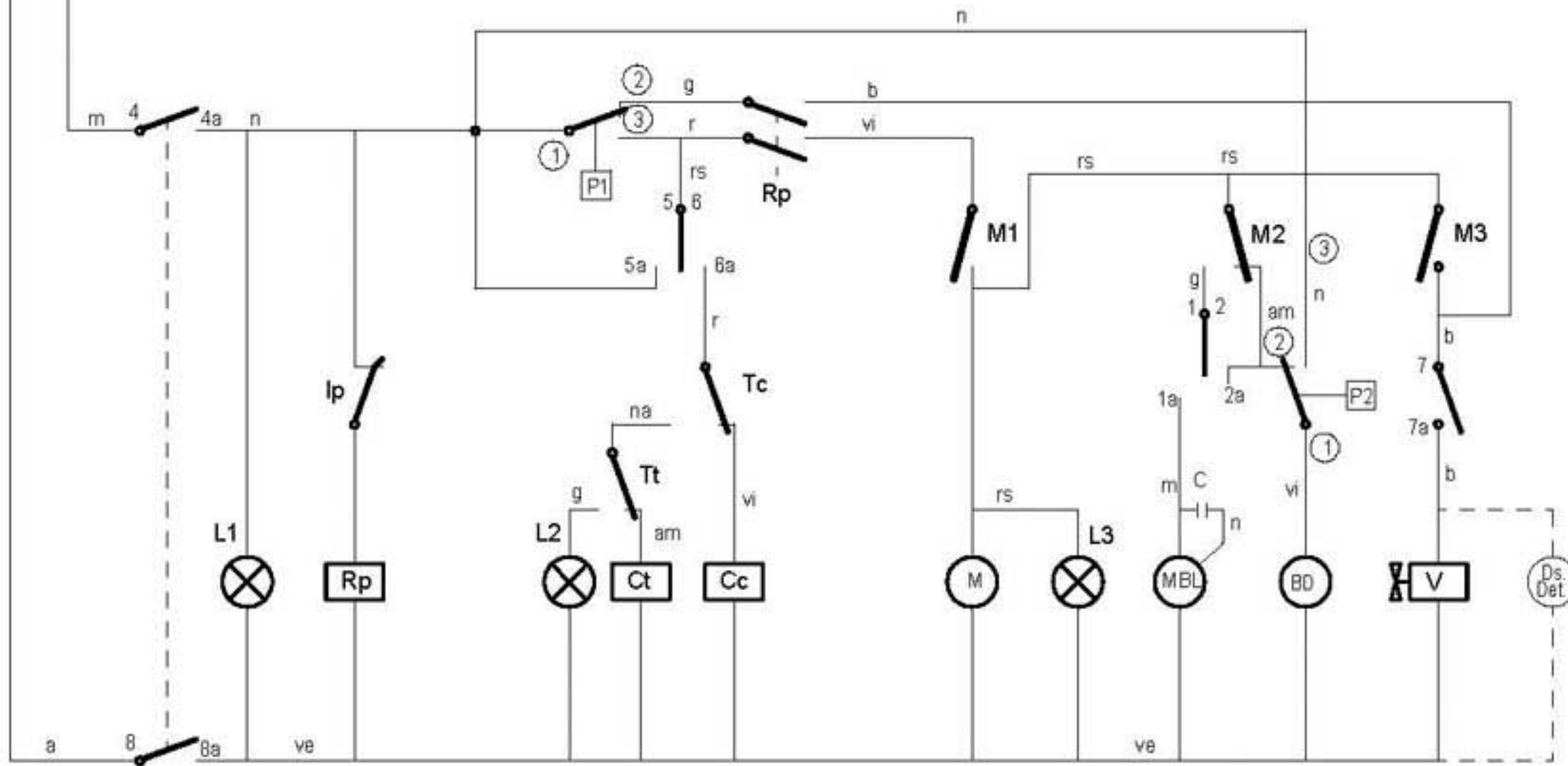

Esquema teorico adhesivo		Z-208807			
Zk/Nº	Pieza	Cant.	Materiala/Material	Klas. zk/Nº Clas	Gainazal akabera/Tratamiento
Zk/Nº	Aldaketa/Modificaciones		Nork. proposatua/Propuesta de	Data/Fecha	Perdoi orkorrak Tolerancias generales
-	-	-	-	-	< 5 ± 0.2
-	-	-	-	-	50 - 100 ± 0.8
-	-	-	-	-	5 - 25 ± 0.4
-	-	-	-	-	> 100 ± 1
-	-	-	-	-	25 - 50 ± 0.6
-	-	-	-	-	α ± 1
Marratzua/Dibujado	S. N.	Data/Fecha	 Fagor Industrial, Koop. Elk. Mugatua		Gainazal perdoia Mecanizado superficial
Proiektatua/Proyectado					-
Egiatzatua/Comprobado					-
Eskala/Escala	LAVAVAJILLAS				Plano Zk./Plano Nº
-					HC-16504
Plano hau ezin daiteke erabili, ez berriztatu, gure baimenik gabe.					- Zk. ord. du
					- Zk. gaitik ord.

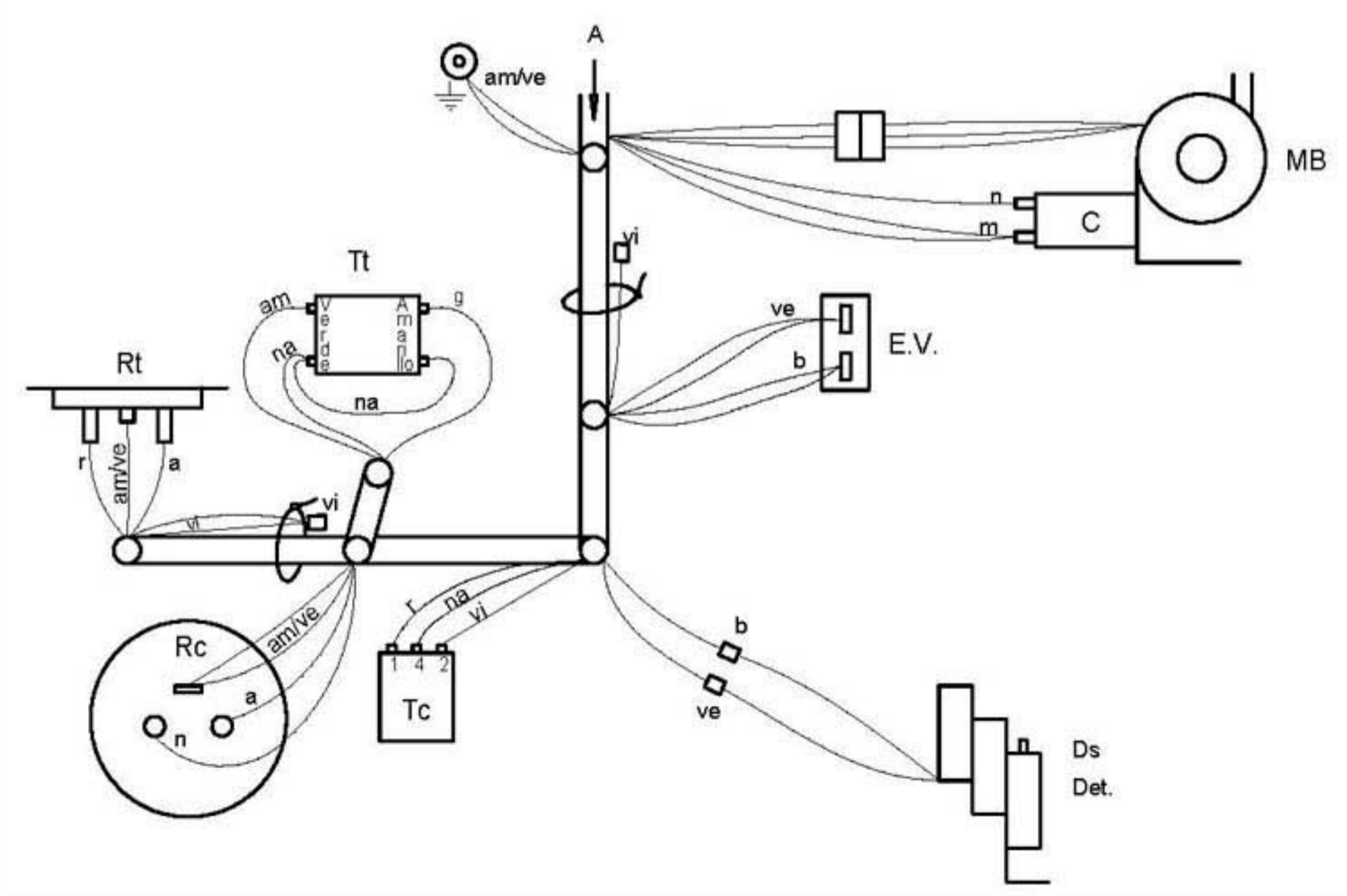
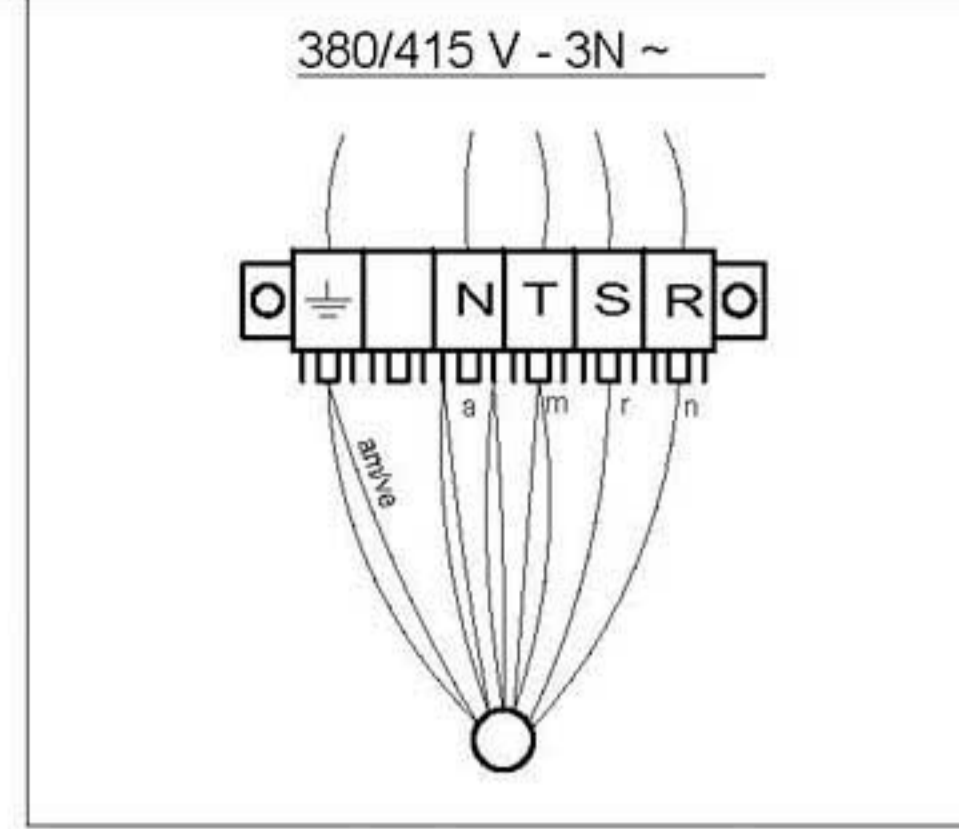
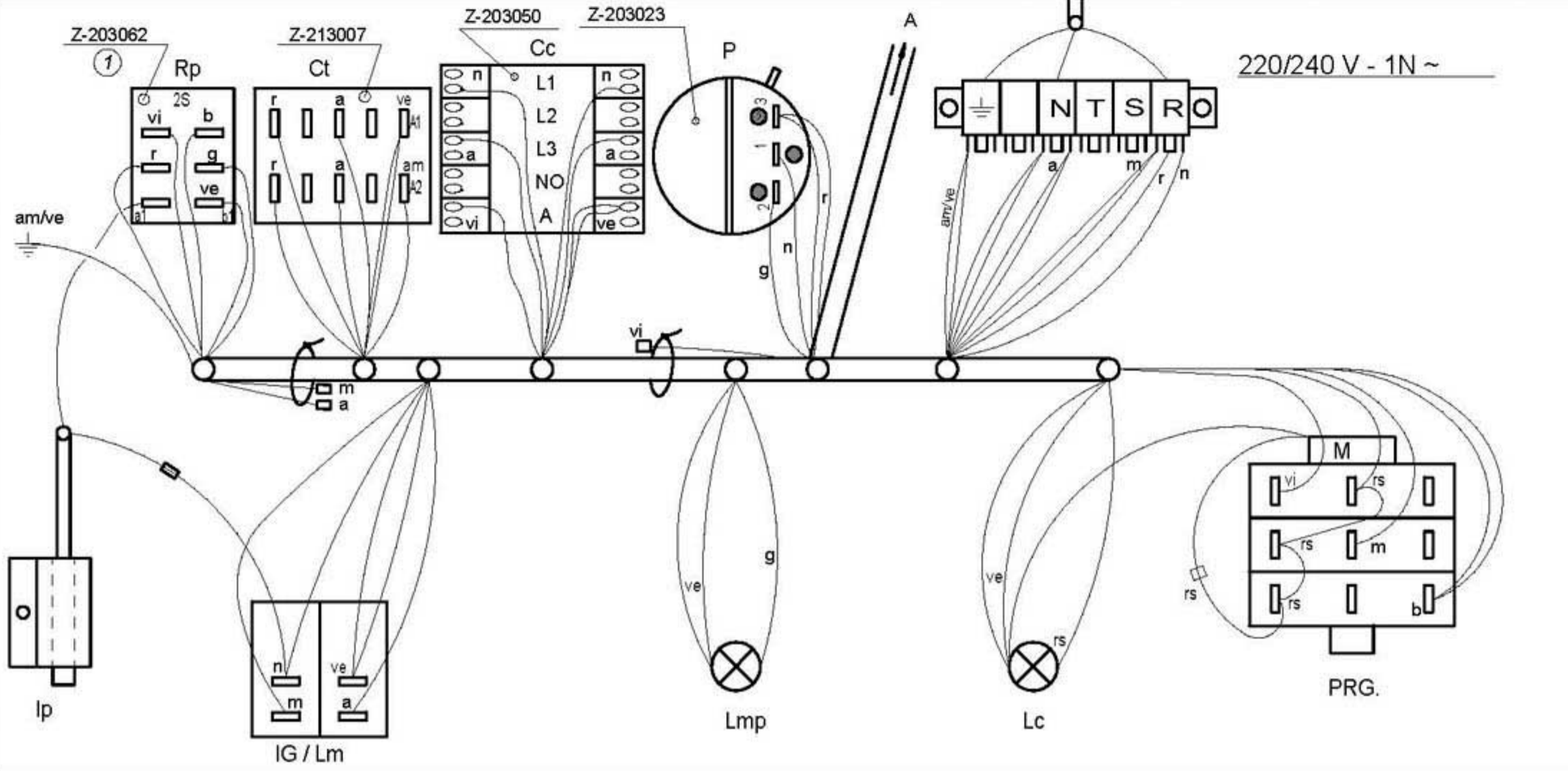

Esquema de montaje FI-30		Z-203051							
Nº Pieza	Material	NP Clasificación	Acabado						
Nº Modificación	Propuesta de	Fecha	Tolerancias generales						
1 Sustituir relé Z-203018 por Z-203062, cambiar colores en Rp	J.M.P.A.	13-05-02	<table border="0"> <tr> <td><5±</td> <td>50-100±</td> </tr> <tr> <td>5-25±</td> <td>>100±</td> </tr> <tr> <td>25-50±</td> <td>∞±</td> </tr> </table>	<5±	50-100±	5-25±	>100±	25-50±	∞±
<5±	50-100±								
5-25±	>100±								
25-50±	∞±								
Dibujado	Firma	Fecha	 Fagor Industrial, Koop. Elk, Mugatua						
Proyectado	Santi Caro	07-07-00							
Comprobado									
Escala			Mecanizado superficial						
LAVAVAJILLAS			Plano numero						
			HC-17262-1						
			Sustituye al N° HC-16176						
			Sustituido por						
Plano hau ez dateke erabil ez berriz gure baimentz gabe									

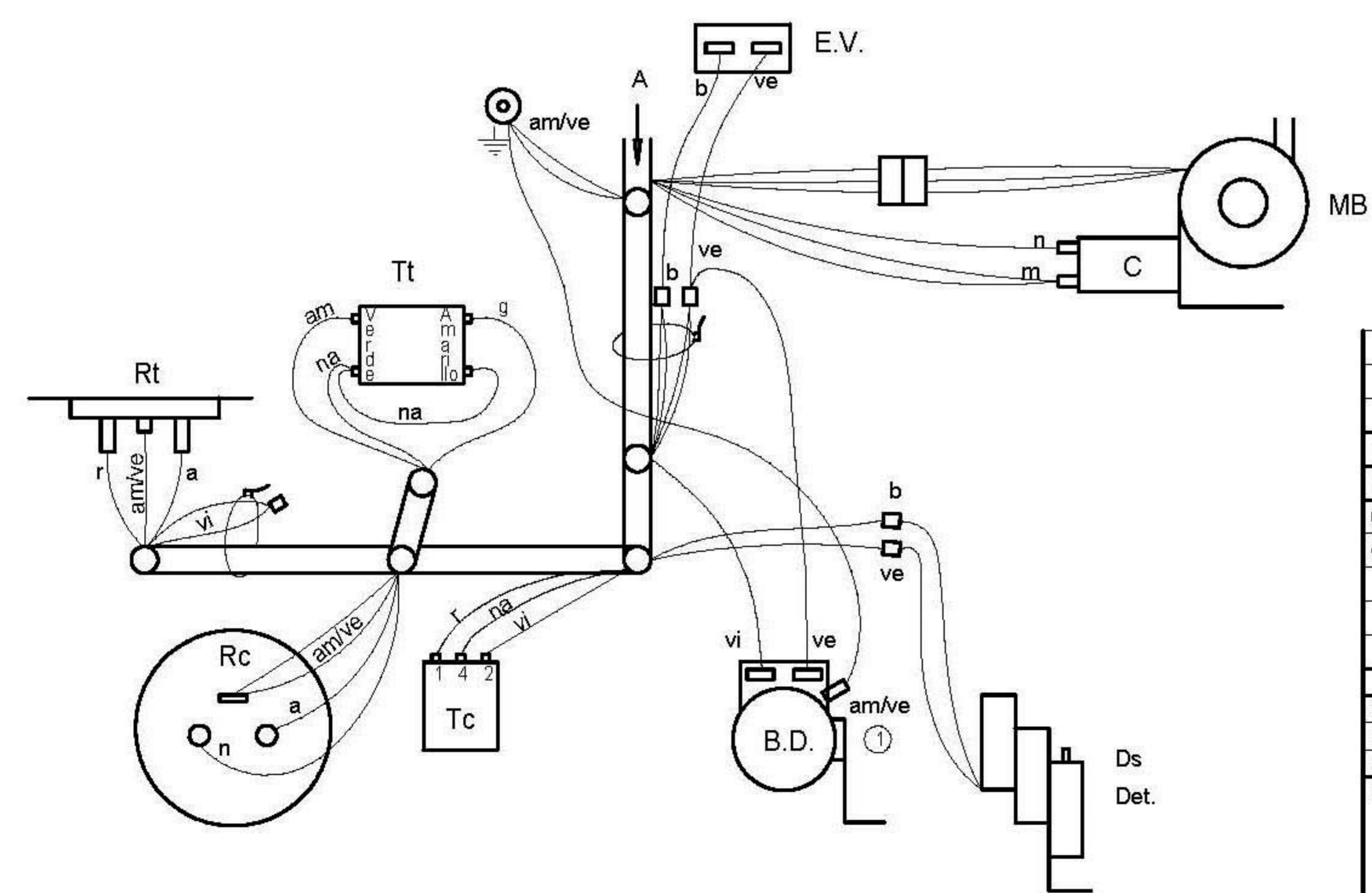
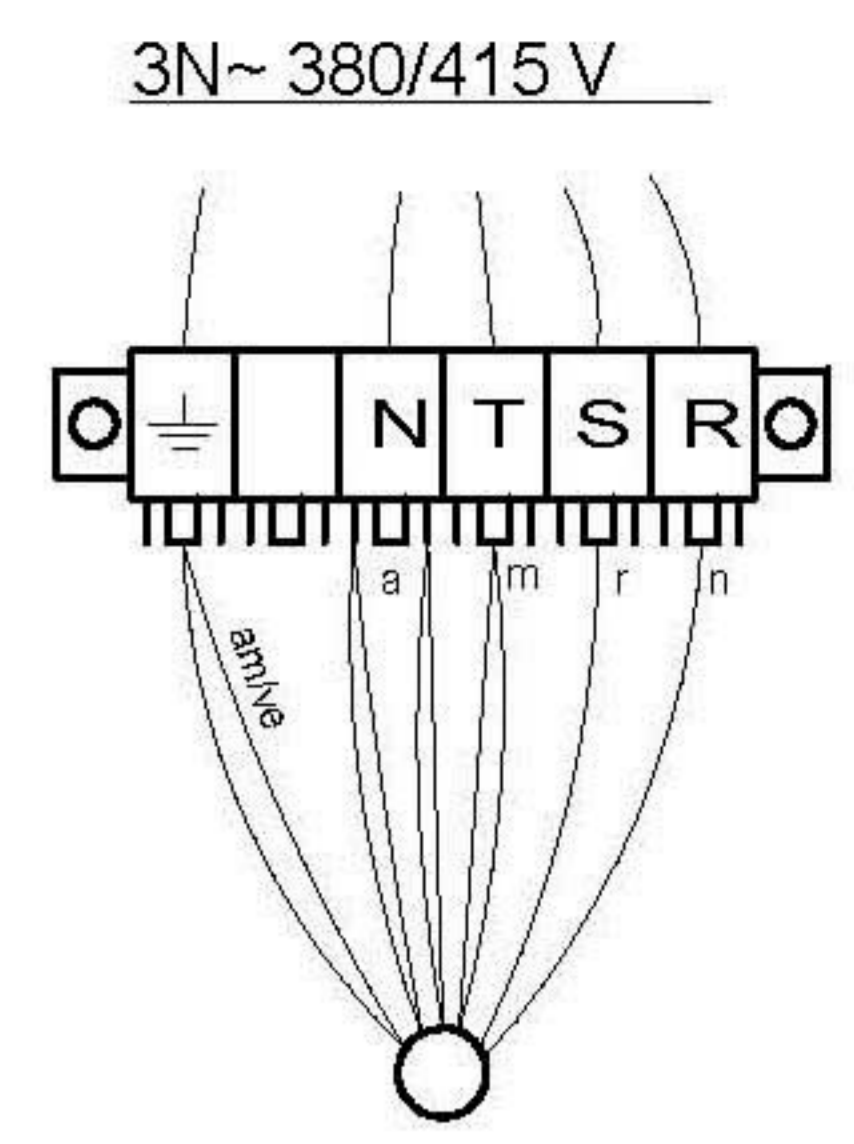
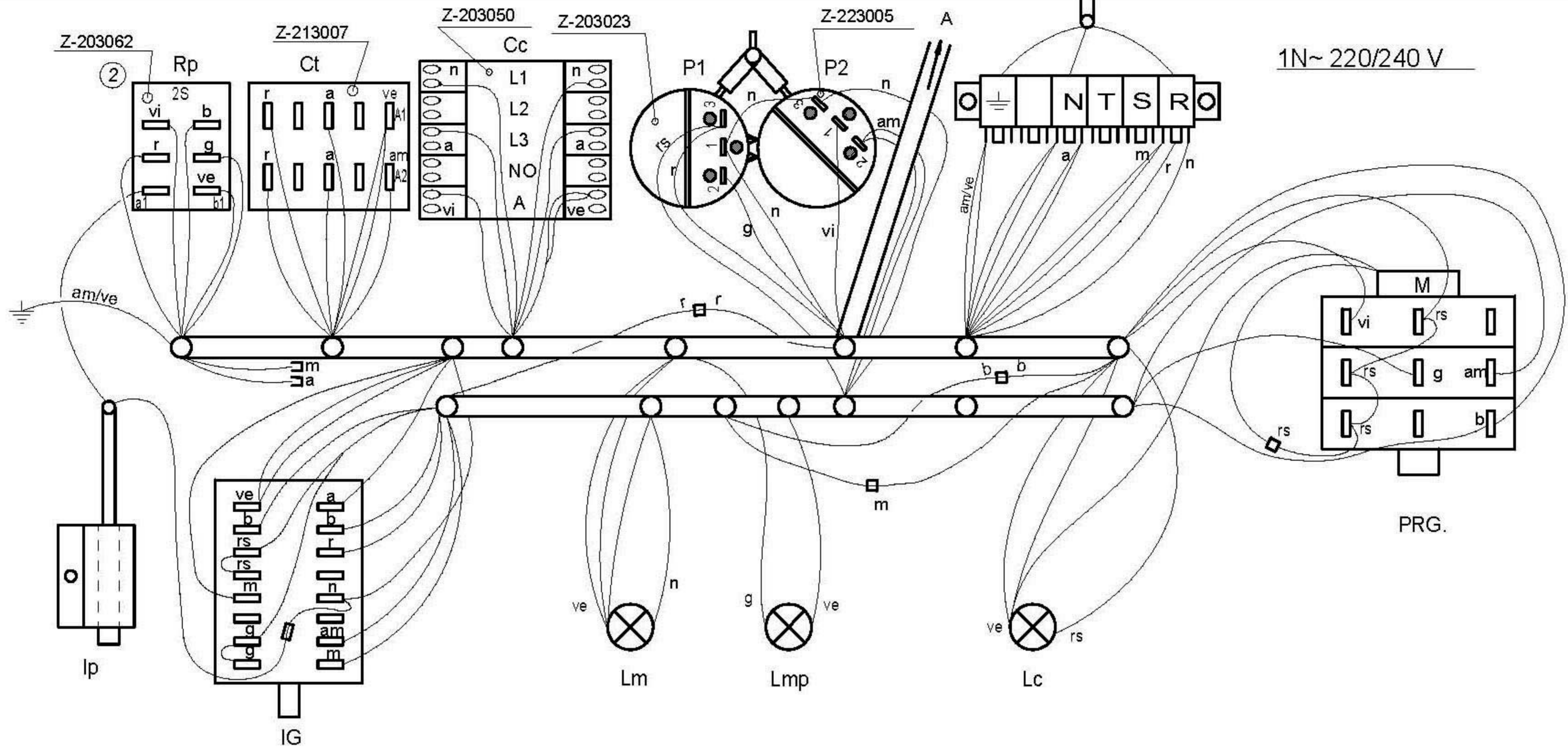

Esquema de montaje FI-30B				Z-208808		
Nº	Pieza	Cant.	Material	Nº Clasificación	Acabado	
Nº	Modificación		Propuesta de	Fecha	Tolerancias generales	
1	Añadir cable tierra en bomba desague		Santi	4-6-2001	<5± 5-25± 25-50±	
2	Sustituir relé Z- 203018 por Z- 203062, cambiar colores en Rp		J.M.P.A.	02-05-13		50-100± >100± ∅±
Dibujado		Firma	Fecha	Mecanizado superficial		
Proyectado		Santi Caro	07-07-00	FAGOR		
Comprobado				Fagor Industrial,Koop.Elk, Mugatua		
Escala					Plano numero	
LAVAVAJILLAS					HC-17264 -2	
					Sustituye al N°	HC-16331
Plano hau ez daiteke erabil ez berriz gure baimentz gabe						