

Multi-functional Food mixer

INSTRUCTION MANUAL

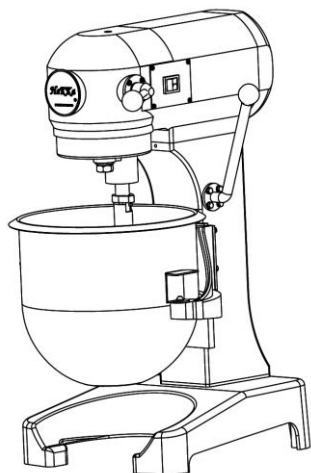

M20

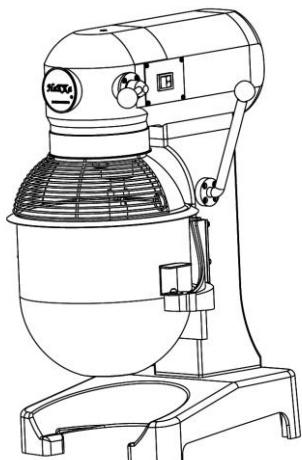

M20B

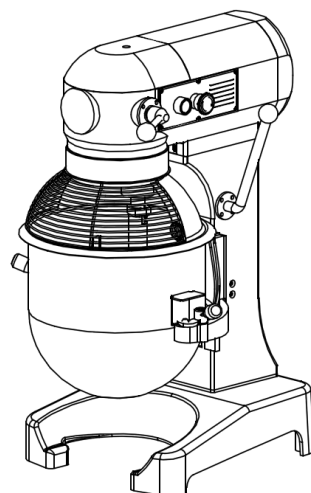

M20A

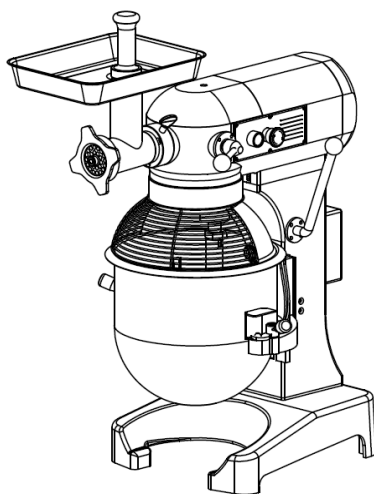

M20A-4





● PLEASE READ INSTRUCTION THOROUGHLY BEFORE USING THE EQUIPMENT

1 CONTENT

1. Content.....	P1
2. All Bakery Solution.....	P2
3. Front View	P3
4. Gear Box Body.....	P4
5. Axis Assembly	P5
6. Gear Assembly.....	P6
7. Worm Gear Assembly.....	P7
8. Motor Assembly.....	P8
9. Transmission fork assembly.....	P9
10. Base, Pedestal, Bowl Up and Down System.....	P10
11. Planetary Base, Mixing Shaft System.....	P11
12. Bowl Support System.....	P12
13. Standard Parts.....	P13
14. Meat Grinder System (Optional).....	P14
15. Electrical wiring diagram (equipped with 24V transformer and protection switch).....	P15
16. Installation of a protection switch circuit diagram.....	P16
17. Route map.....	P17
18. Operation.....	P18
19. Attention.....	P19
20. Fault handling and technical parameters.....	P20
21-22. Exploded.....	P21-22
23. WARRANTY CARD.....	P23

2 ALL BAKERY SOLUTION

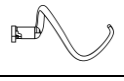
HAKKA series multifunctional mixer are the food processing machine which are complete with modern designed and meet with domestic and international market; Integrated machine body; Cast iron base, premium Stainless steel bowl, bowl guard; Gear-Driven Transmission:Reliable, durable, and consistent performance.Minimum downtime with positive drive under heavy This products series have approved by CE.

Item No.	M20	M20B	M20A	M20A-4
Capacity (L)	20	20	20	20
Voltage(V)	110/220/380	110/220/380	110/220/380	110/220/380
Rated frequency (HZ)	50/60	50/60	50/60	50/60
Rated input power (W)	1100	1100	1100	1100
Mixing speed (r/min)		404	404	404
		225	225	225
		125	125	125
		----	----	----
				46-87-156

3 Front View

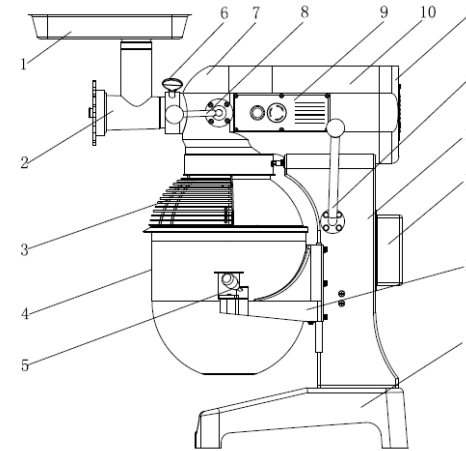

	Name	Qt.	Note
1.	Stuff tray	1PCS	Option
2.	Meat Grinder Head	1 SET	Option
3.	Protect Cover	1 SET	Option
4.	Bowl	1PCS	
5.	Bowl Lock arm	2 SET	
6.	Lock-screw	1PCS	Option
7.	Top Cover	1PCS	
8.	Transmission Handle	1PCS	
9.	Name Plate	1PCS	
10.	Body	1PCS	
11.	Rear Cover	1PCS	
12.	Up and Down Handle	1PCS	
13.	Pedestal	1PCS	
14.	Electric Box	1PCS	
15.	Bowl Support	1PCS	
16.	Base	1PCS	

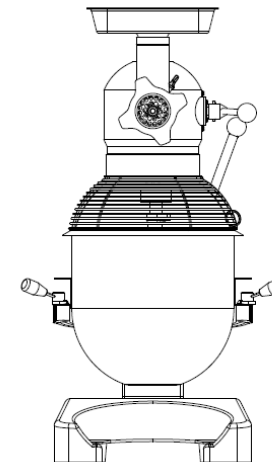

Noted :

Do not use the water spray to cleaning the machine .

Do not contact switches and power plug with your wet hand .

When repairing the machine, must first pulled out power plug, and the professional workers do it .

4 Gear Box Body

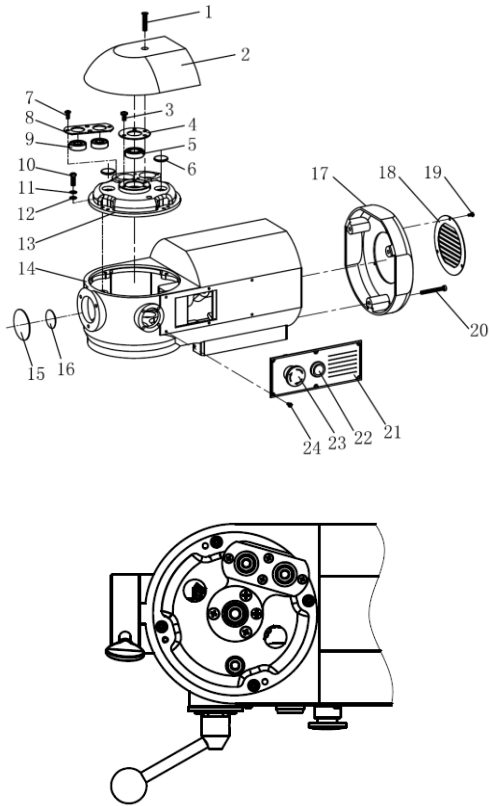

	Name Of Part	Qt.	Note
1.	Sunk screw M6x35	1PCS	
2.	Top Cover	1PCS	
3.	Cup Head Screw M16*12	3PCS	
4.	Pressure Plate	1PCS	
5.	Bearing 6003	1PCS	
6.	Bearing Cap	2PCS	
7.	Cup Head screw M5X10	4PCS	
8.	Double orifice linking piece	1PCS	
9.	Bearing 6201	2PCS	
10.	Inner Hexagon Screw m6*20	4PCS	
11.	Spring washer	4PCS	
12.	Flat gasket	4PCS	
13.	Bearing Block	1PCS	
14.	Body	1PCS	
15.	Name plate	1PCS	
16.	Front end cap	1PCS	
17.	Rear cover	1PCS	
18.	Rear air window	1PCS	
19.	Cup Head Screw M4*8	3PCS	
20.	Inner Hexagon Screw M6*50	3PCS	
21.	Name Plate	1PCS	
22.	Start switch	1PCS	Optional
23.	Emergency switch	1PCS	Optional
24.	Cup Head Screw M4*8	6PCS	

Noted:

Before the machine goes out of the hakka factory, it has been applied with high quality lubrication grease (Lithium base lubrication grease #42) sufficient, for about 3-4 years of operation. But after the machine maintenance, lubrication grease have to be prevent maintenance accidentally the screws fall into or other thing damage machine.

Please don't open the head at will, unless it is internal worm or gear and related parts have problem.

The cover must be tight after filled with grease. After maintenance, each screws have to be tighten.

5 Axis Assembly

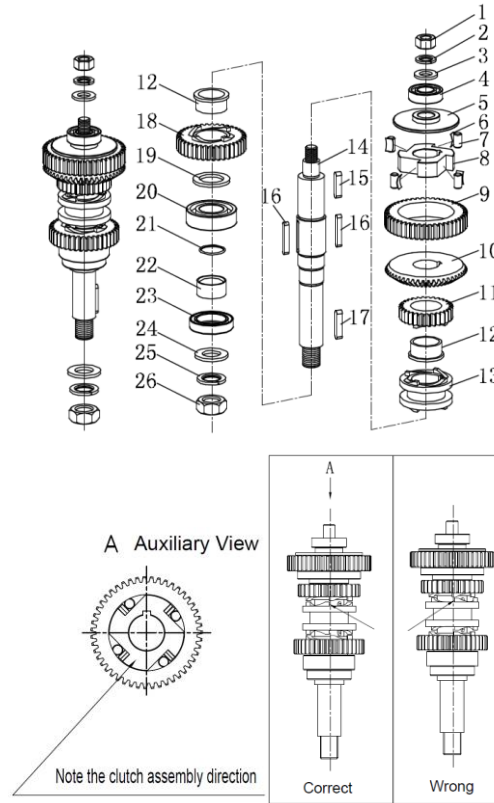

Please note joint gear and jointer must be corresponding direction, can't reverse.

Noted:

5.1. When you demolition or assembling, please be careful, avoid to damage spare parts

5.2. After installation and maintenance: Check the clutch direction whether same as sketch map.

5.2.1. Check the joint gear and jointer einbaurichtung, whether same as correct sketch map.

5.2.2. Check the joint gear and jointer einbaurichtung, whether same as correct sketch map.

5.3. After installation and maintenance, try running the machine, check if there is oil dropped. If have oil to distill, please check the framework oil seal # 23 if it is damaged..

	Name	Qt.	Note
1.	Hexnut M12	1PCS	
2.	Spring washer	1PCS	
3.	Flat gasket	1PCS	
4.	Bearing 6003	1PCS	
5.	Clutch Cover	2PCS	
6.	Spring lamination	4PCS	
7.	Steel column $\phi 8*15$	4PCS	
8.	Clutch Base	1PCS	
9.	Gear (Z=47)	1PCS	
10.	Angle Gear(Z=47)	1PCS	
11.	Joint Gear(Z=30) for 60HZ	1PCS	
11.	Joint Gear(Z=29) for 50Hz	1PCS	
12.	Bearing Bush	2PCS	
13.	Clutch	1PCS	
14.	Center shaft	1PCS	
15.	Flat key 6*6*28	1PCS	
16.	Flat key 5*5*35	1PCS	
17.	Flat key 6*6*32	1PCS	
18.	Joint gear(Z=39)	1PCS	
19.	Center shaft washer	1PCS	
20.	Bearing 6205	1PCS	
21.	Seal ring	1PCS	
22.	Sleeve	1PCS	
23.	Framework oil seal 30*45*10	1PCS	
24.	Flat gasket	1PCS	
25.	Spring washer	1PCS	
26.	Hexnut M18	1PCS	

6 Gear Assembly

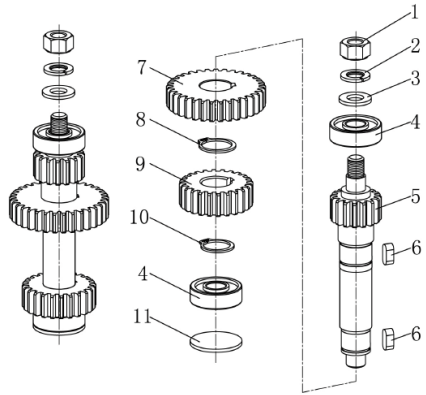

	Name	Qt.	Note
1.	Hexnut M10	1PCS	
2.	Spring Washer	1PCS	
3.	Flat gasket	1PCS	
4.	Bearing 6201	2PCS	
5.	Gear shaft	1PCS	
6.	Flat key 5*5*12	2PCS	
7.	High-spead gear(Z=33) for 60Hz	1PCS	
7.	High-speed gear(Z=26) for 50Hz	1PCS	
8.	Washer on shaft φ 20*1.2	1PCS	
9.	Low speed gear(Z=24)	1PCS	
10.	Washer on shaft φ 18*1.2	1PCS	
11.	Gear shaft gasket	1PCS	

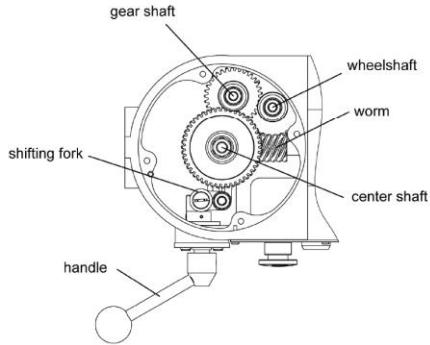

Noted:

- 6.1.Maintenance must according to this : center shaft -gear shaft-wheelshaft
- 6.2.Assembly sequence is wheel shaft-gear shaft-center shaft .
- 6.3.When repair the gear shaft and wheel shaft, from down (there is a hole below the body) to up by beating, before put into the gear shaft gasket , please use sealant avoid to oil leak .

4.After repair , please check the gear gear box without any other sundry before apply with lubricaton grease .

7 Worm Gear Assembly

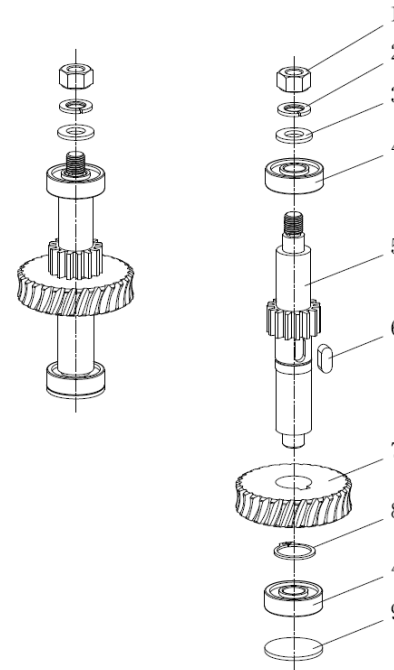

	Name	Qt.	Note
1.	Hexnut M10	1PCS	
2.	Spring Washer φ 10	1PCS	
3.	Flat gasket φ 10	1PCS	
4.	Bearing 6201	2PCS	
5.	Gear shaft (Z=15) for 60Hz	1PCS	
5.	Gear shaft (Z=16) for 50Hz	1PCS	
6.	Flat key 6*6*14	1PCS	
7.	Worm gear (Z=29)	1PCS	
8.	Washer on shaft	1PCS	
9.	Gear shaft gasket	1PCS	

Noted:

Before assemble the machine , please check the washer on shaft whether can use , if it was out of shape or bigger ,please replace it .

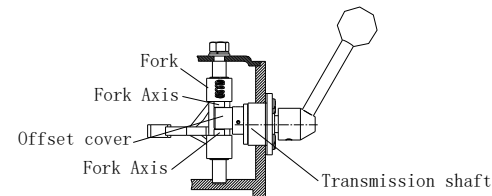

8 Motor Assembly

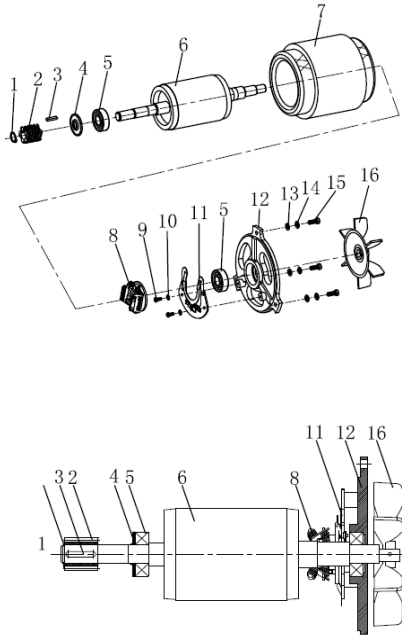

Rotor Assembly Drawing

	Name Of Part	Qt.	Note
1.	Splitpin $\phi 16 \times 1.0$	1PCS	
2.	Worm	1PCS	
3.	Key 4*4*22	1PCS	
4.	Oil seal	1PCS	
5.	Bearing 6203	2PCS	
6.	Motor Rotor	1PCS	
7.	Motor Stator	1PCS	
8.	Centrifugal switch	1PCS	
9.	Screw M4*10	2PCS	
10.	Washer $\phi 4$	2PCS	
11.	Centrifugal switch plate	1PCS	
12.	Rear bearing cover	1PCS	
13.	Washer $\phi 6$	3PCS	
14.	Spring washer $\phi 6$	3PCS	
15.	Screw M6*16	3PCS	
16.	Fan	1PCS	

Note:

- 8.1. After fix motor, if the motor does not work right, please check power supply and the cable at first. Then check the wire connection right or not. And check capacitor damage or not. And check centrifugal switch connect right or not. And check the loading of the bowl heavy or not.
- 8.2. Motor include rotor and stator and stator shaft.
- 8.3. If we need change motor, take down stator need special tools. Please ask our after sales service people supply. After fix, please be carefully to install the stator.
- 8.4. If we found motor have oil leaking, please ask after sales service to change the oil seal.

9 Transmission fork assembly

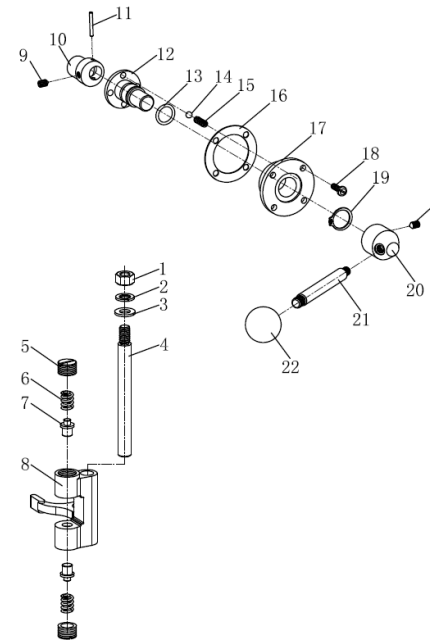

	Name	Qt.	Note
1.	Hex nut M10	1PCS	
2.	Spring washer $\phi 10$	1PCS	
3.	Washer $\phi 10$	1PCS	
4.	Fork Shaft	1PCS	
5.	Fork screw	2PCS	
6.	Fork spring	2PCS	
7.	Fork axis	2PCS	
8.	Fork	1PCS	
9.	Taper screw M6*10	2PCS	
10.	Offset cover	1PCS	
11.	Pin $\phi 3 \times 25$	1PCS	
12.	Transmission shaft	1PCS	
13.	O Oil seal 18*2.4	1PCS	
14.	Steel ball $\phi 6\text{mm}$	4PCS	
15.	Spring	4PCS	
16.	Paper oil seal or oil seal	1PCS	
17.	Transmission base	1PCS	
18.	Transmission name plate	1PCS	
19.	Screw M5*16	4PCS	
20.	Splitpin $\phi 20 \times 1.2$	1PCS	
21.	Transmission handle base	1PCS	
22.	Transmission handle	1PCS	
23.	Transmission handle ball	1PCS	

Note:

After the machine long time use, #10 Offset cover will be abrasion, it will cause not easy transmission, the machine working will cause transmission shaft tremble, if you find the problem, please ask our service agent to change the #7 fork axis and #10 offset cover.

10 Base, Pedestal, Bowl Up and Down System

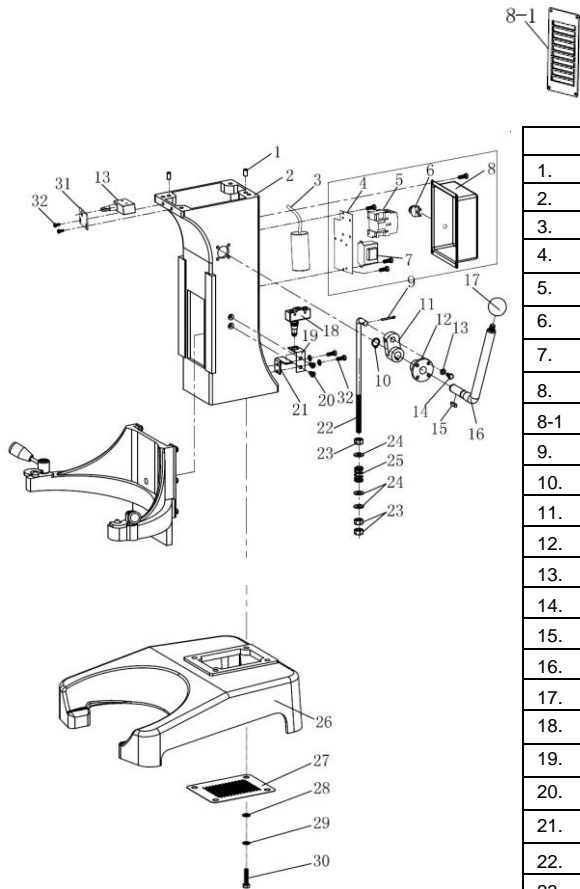

	Name Of Part	Qt.	Note
1.	Pin $\phi 8 \times 15$	2PCS	
2.	Pedestal	1PCS	
3.	Capacitance (25V 200UF)	1PCS	
4.	Electric board	1PCS	For M20A.M20A-4
5.	Cocontactor (CJX2-09)	1PCS	For M20A.M20A-4
6.	Proector ((10A))	1PCS	For M20A.M20A-4
7.	Trans former (20VA)	1PCS	For M20A.M20A-4
8.	Electric Box	1PCS	For M20.M20B
8-1	Back cover	1PCS	
9.	Splitpin $\phi 3$	1PCS	
10.	Splitpin $\phi 16 \times 1$	1PCS	
11.	Brace	1PCS	
12.	Frame	1PCS	
13.	Washer $\phi 6$	4PCS	
14.	Screw M6*12	4PCS	
15.	Key 5*5*20	1PCS	
16.	Up and down handle	1PCS	
17.	Handle ball	1PCS	
18.	Safty switch	1PCS	For M20A.M20A-4
19.	Safty switch frame	1PCS	For M20A.M20A-4
20.	Screw M6*12	2PCS	For M20A.M20A-4
21.	Safty switch paddle	1PCS	For M20A.M20A-4
22.	Tie	1PCS	
23.	Nut M10	3PCS	
24.	Washer $\phi 10$	3PCS	
25.	Bowl support spring	1PCS	
26.	Base	1PCS	
27.	Mouse prevent guard	1PCS	
28.	Washer $\phi 8$	4PCS	
29.	Spring Washer $\phi 8$	4PCS	
30.	Screw M8*35	4PCS	
31.	Frame	1PCS	
32.	Screw M5*10	1PCS	For M20A.M20A-4

11 Planetary Base, Mixing Shaft System

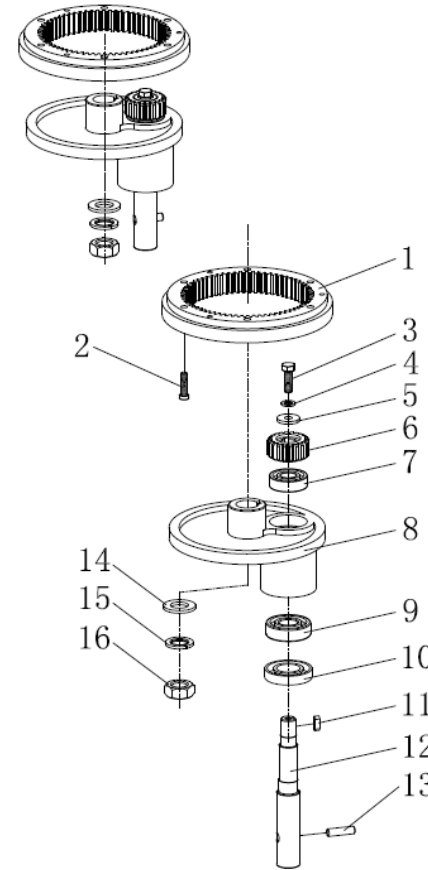

	Name Of Part	Qt.	Note
1.	Gauze(moved)	1PCS	
2.	Internal Gear (Z=67)	1PCS	
3.	Screw M6*25	6PCS	
4.	Gauze(fixed)	1PCS	
5.	Screw M5*12	1PCS	
6.	Screw M8*25	1PCS	
7.	Spring washer $\phi 8$	1PCS	
8.	Washer	1PCS	
9.	Planetary gear(Z=20)	1PCS	
10.	Bearing 6203	1PCS	
11.	Planetary base	1PCS	
12.	Bearing 6204	1PCS	
13.	Oil Sear 25*50*10	1PCS	
14.	Key 5*5*18	1PCS	
15.	Mixing Shaft	1PCS	
16.	Pin $\phi 8 \times 30$	1PCS	
17.	Washer $\phi 18$	1PCS	
18.	Spring Washer $\phi 18$	1PCS	
19.	Nut M18	1PCS	

Note:

When the machine is working, #8 planetary base have deviant noise, maybe #1 internal gear loose lock, you need take #8 planetary base to tighten #2 screw.

12 Bowl Support System

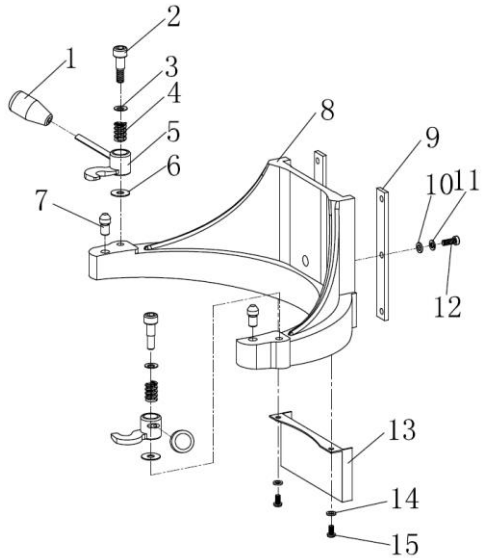

	Name Of Part	Qt.	Note
1.	Bowl locked handle cover	2PCS	
2.	Bowl locked handle screw	2PCS	
3.	Washer	2PCS	
4.	Spring	2PCS	
5.	Bowl locked handle(R &L)	2PCS	
6.	Washer	2PCS	
7.	Bowl pin	2PCS	
8.	Bowl support	1PCS	
9.	Flat plate	2PCS	
10.	Washer ϕ 6	6PCS	
11.	Spring washer ϕ 6	6PCS	
12.	Screw M6*16	1PCS	
13.	Pedestal down safety plate	1PCS	
14.	Washer ϕ 5	2PCS	
15.	Screw M5*10	2PCS	

Note:

Please open bowl locked handle and take down mixing parts when you want to take down bowl.

13 Standard Parts

Dough hook

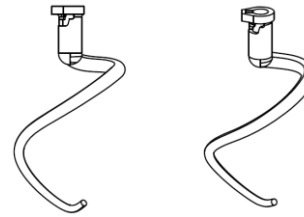

Egg Beater

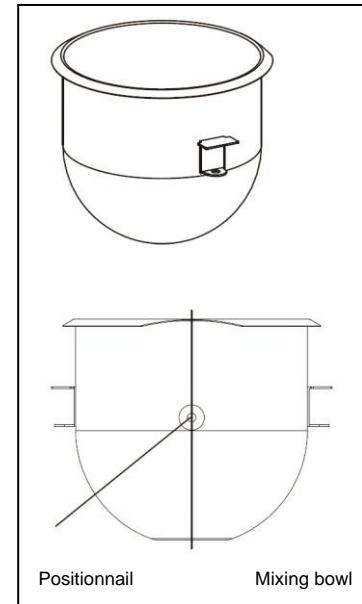
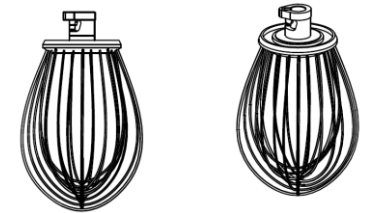

Flat Beater

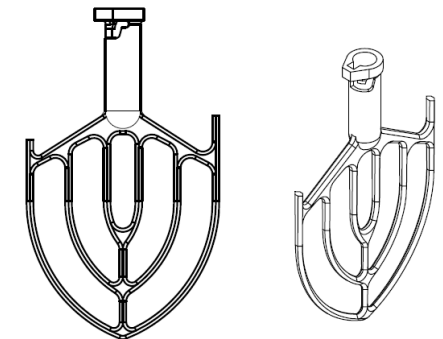

Note: 13.1. When you install mixing parts to mixing shaft, hold and push up to the shaft, then rotate time direction and pull down. If you want take off, hold and push up to the shaft, then rotate time reverse direction to slot and pull down, you can take it off.

13.2. The mixing bowl pin must be right install to the bowl support hole.

14 Meat Grinder System (Optional)

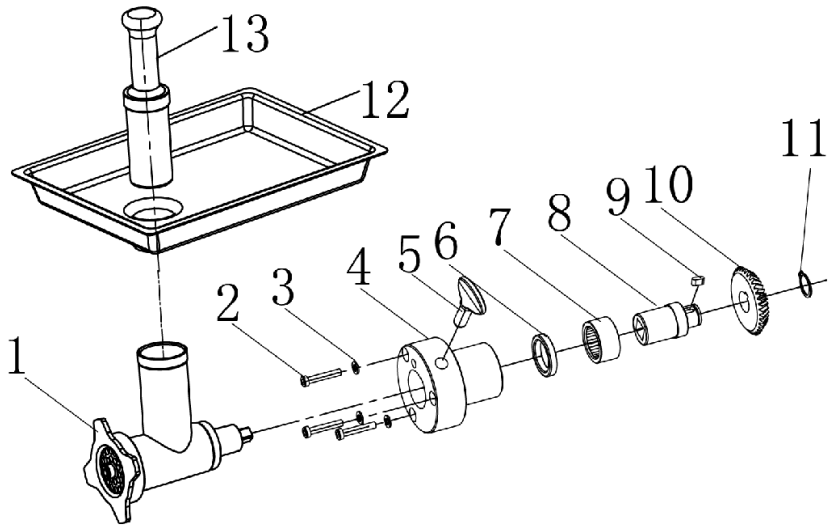

	Name	Qt.	Note
1.	Grinder set	1PCS	
2.	Screw M6*35	3PCS	
3.	Washer φ6	3PCS	
4.	4 function joint	1PCS	
5.	Locked screw	1PCS	
6.	Oil seal 30*40*7	1PCS	
7.	Bearing HK304020	1PCS	
8.	4 function connector for grinder	1PCS	
9.	Key 6*6*12	2PCS	
10.	Small Bevel gear	1PCS	
11.	Splitpin20*1.2	1PCS	
12.	Meat tray	1PCS	
13.	pusher	1PCS	

Note:

14.1. Meat grinder function system set please refer our meat grinder TC12 instruction manual.

14.2. It's an optional function. Please make sure what you need it or not.

15 electrical wiring diagram

15.1.(equipped with 24V transformer and protection switch) For M20A M20A-4

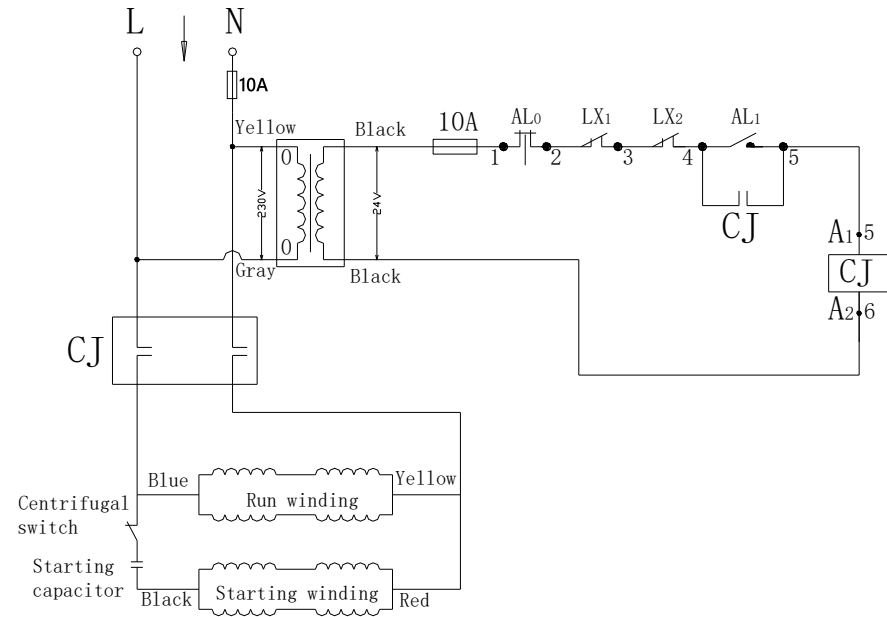

Annotations: CJ —AC contactor

AL₀ —Emergency stop switch。

AL₁ —Start Switch

LX₁, LX₂ —Micro Switch

16 Installation of a protection switch circuit diagram

For M20A M20A-4

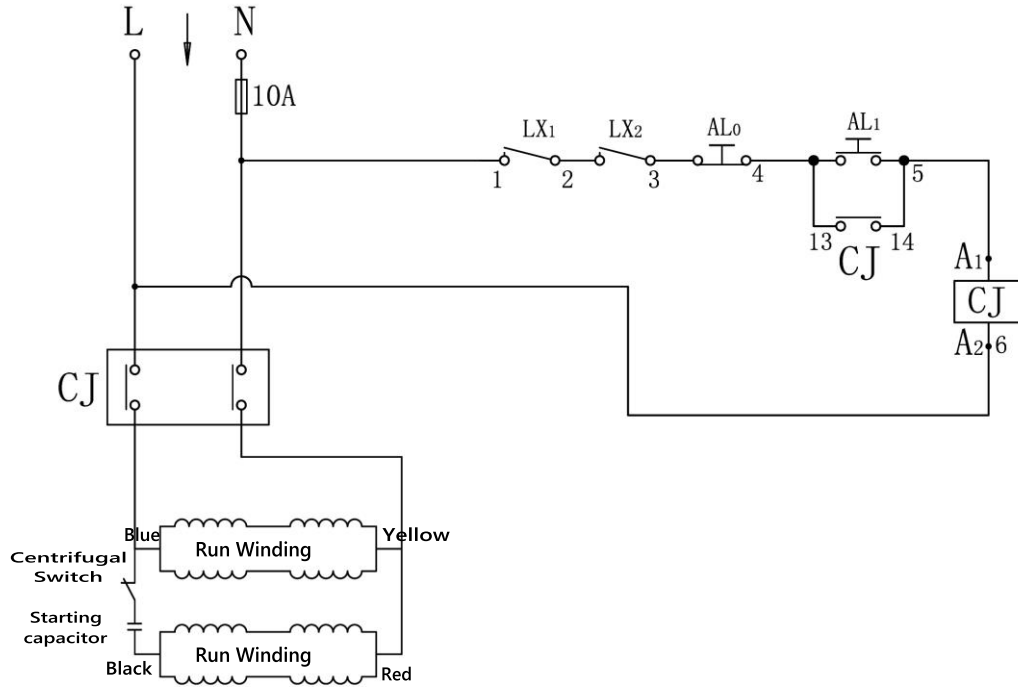

Annotations: CJ—AC contactor

AL₀—Emergency stop switch。

AL₁—Start Switch

LX₁, LX₂—Micro Switch

17 Route map

For M20 M20B

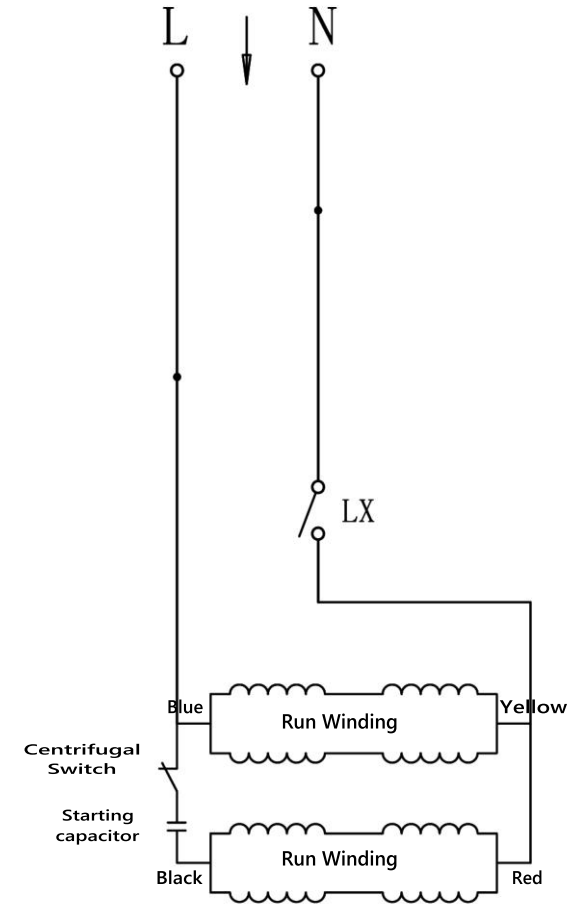

Annotations: AL-- Switch

18 Operation

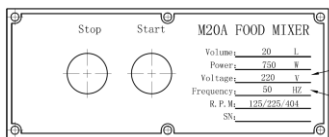
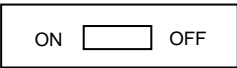

Power
Voltag

Please check your power supply voltage and frequency same as the label show or not before use. Also Out connection ground fix good or not.

Before test can't install



18.1.1 Please don't install all mixing parts before test the machine. Otherwise it will be damage because of wrong turning direction.
 18.1.2 For 3phases machine, please stop immediately if you find planetary base and the indication mark direction are difference. And ask for electrician to make it same direction.
 18.1.3 Attention: Don't use ground wire connect to live wire.

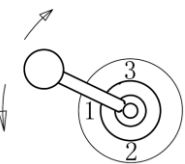

18.2.1 No load test can none stop machine and easy transmission.
 18.2.2 The machine must be stopped if you want change the speed to protect the gear. If the handle not in right position. you can rotate time direction the planetary base by hand, then you can easy change the speed what you need.



18.3.1 Speed 3: 404RPM (Fast speed)
 18.3.2 Use for high speed to mix egg, milk cream, no more than 20min continue working each time.

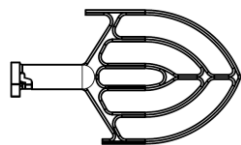

18.4.1 Speed 2: 225RPM (Middle speed)
 18.4.2 Use speed 2 to mixer the stuff or paste etc., no more than 25min continue working each time.



18.5.1 Speed 1: 125RPM (Low speed)
 18.5.2 Use speed 1 to mix the flour to dough, if the water rate between 45% to 55%, no more than 30 min continue working each time.

19 Attention

- 19.1. Please check your power supply voltage and frequency same as the label show or not before use.
- 19.2. Please use ground wire to connect equipotential place () before use. The label must be install back after fixing.
- 19.3. Fixing and install right before use the machine. It must have safety working space.
- 19.4. Everything contact food parts need clean before use. (bowl, egg beater, beater, hook). Please pay attention to avoid hurt hand for some sharp place of parts. Don't use water spay the mixer body.
- 19.5. The mixing bowl pin must be right install to the bowl support hole.
- 19.6. When you choose egg beater, beater, hook, please refer the speed what you need. Otherwise it will cause the machine parts damage or shortage the machine life.
- 19.7. Close to the machine running against children.
- 19.8. Not allowed to touch switches and power plug with wet hands.
- 19.9. In use if there is a sudden abnormal sound heard should stop immediately, find a professional inspection, maintenance and repair personnel.
- 19.10. Clean and put safety sanitary place everything what you use after use the mixer. And you should have cut down the power supply.
- 19.11. Always check the power cord for damage, if they are damaged to immediately find a professional replacement.
- 19.12. To keep the machine dry and the surrounding environment, health, safety.

20 Fault handling and technical parameters

Fault	Problem	Exclude method
Press the start switch the machine is not running	Power supply problems	20.1.1.Check the power cord 20.1.2.Check the power supply fits this machine nameplate or not
	Electrical contact problems	20.2.1.Check whether the emergency stop switch open 20.2.2.check the nets safety (#32)switch in place or not 20.2.3.Check the bowl support lifting safety switch in place
Motor speed to reduce overheating	Voltage less than	Check whether the voltage of the machine nameplate
	Inappropriate choice of mixing speed	By instructions to select the appropriate gear speed
Gear box noise and overheating	Poor lubrication	Add grease
Heavy lifting	Guide rails rusty or sticky dirt	Cleaning and lubricating the rails
Mixing parts crash with bowl	Mixing parts and bowl Deformation	Correct mixing parts, bowl, or replacement
The motor running but no high, middle, low speed out to mixer shaft	Worm bad at key	Change the key
	Worm wheel or worm wheel key bad	Change the worm wheel or worm wheel key
	worm wheel shaft fracture	Change the worm wheel shaft
	Gear shaft fracture	Change gear shaft
It has high, middle speed, but no low speed.	Bad internal gear	Change ring gear
	Bad clutch spring	Change clutch spring
	Bad clutch steel column	Change clutch steel column
Center axis of oil leakage	Central axis oil seal broken	Change central axis oil seal
	Central axis O oil seal broken	Change central axis O oil seal

21 M20A.M20A-4.M20B Food Mixer

21.1.Exploded view

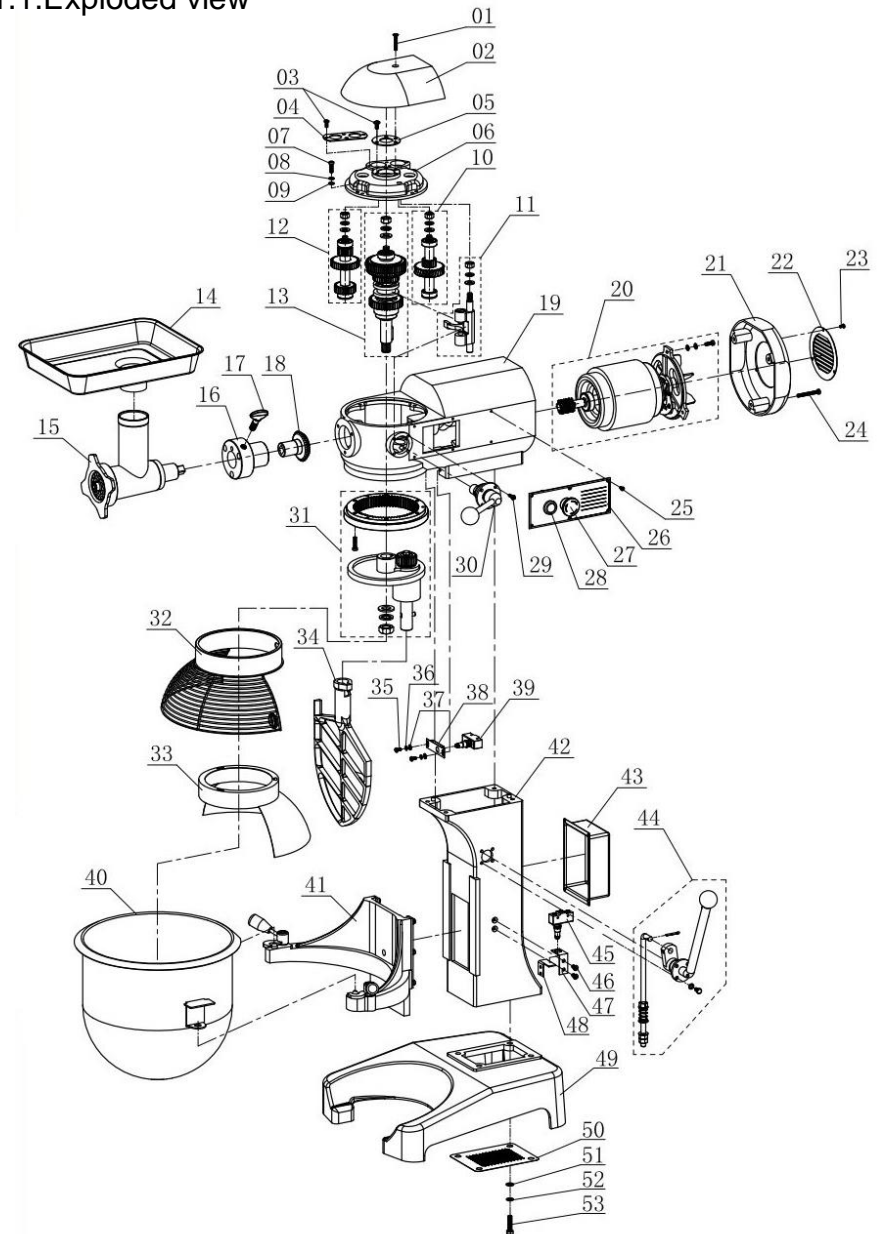

22 M20A.M20A-4.M20B Food Mixer

22.1.Spare parts list

No	Name	Note	No	Name	Note
1	Screw M6X35		28	A-380V switch	M20A M20A
2	Top cover		29	Screw M5X16	
3	Screw M6X12		30	Change speed assembly	
4	Double orifice piece		31	Turn a stirring shaft assembly	
5	Center hole piece		32	Moved protect cover	M20B M20A M20A-4
6	Bearing seat cover		33	Fixed protect cover	
7	Screw M6X20		34	Mixing beat	
8	Spring Washer 6		35	Screw M5X10	M20A M20A
9	Flat gasket 6		36	Spring washer 5	M20A M20A
10	Worm wheel components		37	Flat gasket 5	M20A M20A
11	Fork shaft assembly		38	Position switch frame	M20A M20A
12	Gear assembly		39	Position switch	M20A M20A
13	Center shaft assembly		40	Bowl	
14	Grinding pan	M20A-4	41	Bowl frame	
15	Grinding head	M20A-4	42	upright	
16	Flange knot	M20A-4	43	Electric box	M20A M20A-4
17	Locking screw	M20A-4	44	Lift Handle (full set)	
18	Bevel pinion	M20A-4	45	position switches	M20A M20A-4
19	Body		46	Screw M6X12	M20A M20A-4
20	Motor assembly		47	Lift switch frame	M20A M20A-4
21	Back fan cover		48	Position switch plate	M20A M20A-4
22	Back window		49	Base	
23	Screw M4X8		50	Ratproof screening	
24	Inner hexagon screw M6X50		51	Flat gasket 8	
25	Screw M4X8		52	Spring washer 8	
26	Name plate		53	Outer hexagonal screw M8X35	
27	Emergency switch	M20A M20A-4			

WARRANTY REGISTRATION RELEASE TYPE OR PRINT CLEARLY

NAME _____
 ADDRESS _____
 CITY _____ STATE _____ ZIP CODE _____
 PHONE _____ PURCHASE DATE _____
 PRODUCT MODEL: _____

Purchased for: Commercial use Personal use Other
 Purchased by: _____
 Products purchased from: Store Internet

THIS CARD MUST BE SENT TO THE STORE WHERE YOU
 PURCHASED TO VALIDATE WARRANTY

WARRANTY REGISTRATION RELEASE TYPE OR PRINT CLEARLY

NAME _____
 ADDRESS _____
 CITY _____ STATE _____ ZIP CODE _____
 PHONE _____ PURCHASE DATE _____
 PRODUCT MODEL: _____

Purchased for: Commercial use Personal use Other
 Purchased by: _____
 Products purchased from: Store Internet

THIS CARD MUST BE SENT TO THE STORE WHERE YOU
 PURCHASED TO VALIDATE WARRANTY