

EPF3721GR

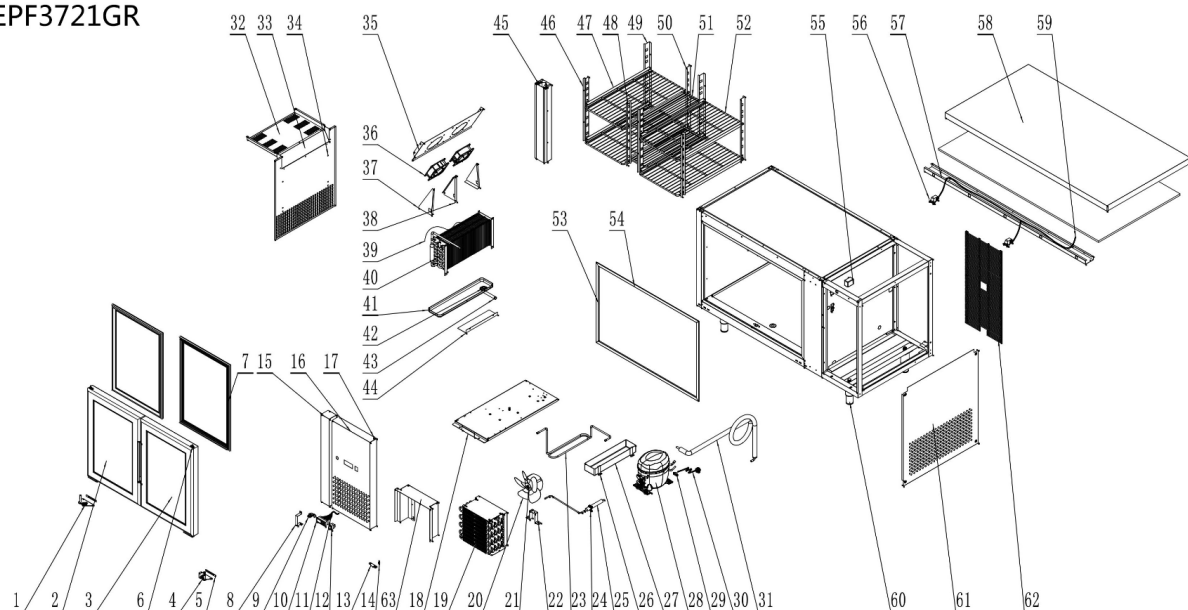

NO	NAME	ENGLISH NAME	CODE	MATERIAL	Q
1	左铰链	Door Hinge-Left	W0604054	SUS304油磨	
2	玻璃门左(大)	Glass Door-Left	37210300L	组件	
3	玻璃门右(大)	Glass Door-Right	37210300R	组件	
4	右铰链	Door Hinge-Right	W0604055	SUS304油磨	
5	铰链衬板	Hinge Stopper	34620521	δ 0.5x12x85/SUS430 油磨	
6	铰链轴	Hinge Axis	B0604111	Φ 10x31/M5-13/材料201/沙拉柜通用件	
7	玻璃门封条(大)	Glass Door Gasket	W0404025	插脚中心:590x3880/软质PVC黑色/F17截面	
8	前罩锁座	Lock Pedestal	34620603	δ 1x15x164/SUS304油磨	
9	冰箱锁	Locker	W0604007	厂家型号:103-20P/锁舌长度:46mm	
10	220V电子温控(R)	Digital Controller	W0302160	XR03CX-5R0C1	
11	欧款冷藏工作台线束	Wire Harness	W0303577	连接温控压缩机蒸发风机	

	(主线)			
12	防水船形开关	Power Switch	W0308019	AC16A_250V/4脚(双刀单掷)/红色指示
13	机房前罩下铰链	Front Panel Hinge-Bottom	1514201	δ 1.5x51x36 /430
14	机房前罩下铰链轴	Front Panel Hinge Axis-Bottom	B0604116	Φ8x27-430不锈钢
15	箱体小前罩	Small Panel	34621601	δ 0.5x801x205/SUS304油磨
16	机房前罩	Front Panel	34620605	δ 0.7x444.4x759.4/SUS304油磨
17	机房前罩上铰链轴	Front Panel Hinge Axis-Top	B0604115	Φ6x28-430不锈钢
18	机组底板	Bottom Plate	34620523	δ 2.0x671x296/热镀锌板
19	钢丝冷凝器	Condenser	W0203047	Φ6邦迪管 黑色电泳处理
20	Φ200风叶	Fan Blade	W0301060	Φ200/V-28度/吸风
21	微光YZF5-13风机	Fan Motor	W0301914	TY-DQ-044
22	风机支架	Fan Motor Bracket	W0604079	高度: 67mm/风机安装Φ4-18Φ4-26/底部脚孔Φ6.5间距82
23	冷凝盘管	Condense Coil	W0210424	Φ7.94x0.75铜管1.3米 (EMT65HLR)
24	日光灯卡子(小)	Clip	W0409255	白色塑料
25	干燥过滤器	Dry Filter	W0204101	Φ2.5-Φ5.2-Φ19x165/XH-9
26	接水盘固定脚	Fixer	34220224	92.5x20、1.0 镀锌板
27	冷凝接水盘	Drain Pan For Condensation	W0411208	ABS/内尺寸346x81
28	R600a压缩机	Compressor	W0201134	EMB46CLC-513300430
29	欧式电源线固定卡	Clip For Cord	W0309006	外形尺寸35 x 16 x 10

30	法式电源线	Power Cord	W030511401	法式插头16A/3x1.0mm ² /长2600/剥皮不浸锡/黑色
31	回气管	Suction Coil	W0210478	Φ9.52x0.6x1100/毛细管内径1.2外径2.4, 1900mm, 出口Φ8.5
32	风道板2	Airflow Plate 2	34620412	δ 0.5/259x462/SUS201油磨
33	风道板1	Airflow Plate 1	34620415	δ 0.5/512.5x116/SUS201
34	蒸发器罩板	Cover Palte For EVAP.	34620401	δ 0.5x594x524/SUS304油磨
35	蒸发风机支架	Fan Motor Plate	34620433	δ 1.0/SUS201油磨/540x210
36	12038直流风机	Fan Motor	W0301112	DC12~26.8V/0.3A/3W/3200RPM/大于132CFM/7.8mmH ₂ O/飞机头反端接线方式
37	蒸发风机左右风道板	Airflow Plate-LR	34620434	δ 0.5/SUS201油磨/203x117
38	蒸发风机中间风道板	Airflow Plate-M	34620435	δ 0.5/SUS201油磨/190x133.5
39	1.5米电子温控器探头	Probe	W0302199	NTC015HP00-C
40	蒸发器	Evaporator	W0202041	竖7排管子, 横5排管子, 6mm翅片间距
41	蒸发接水盘	Drain Pan	W0411215	460x105x20/ABS
42	直冷平调落水管盖	Drain Pipe Cover	W0409099	白色ABS
43	直冷平调落水管	Drain Pipe	W0409098	白色ABS
44	接水盘支撑	Support for Drain Pan	34620418	δ 0.5/256x89 SUS201
45	中梁	Mullion	34620310	组件
46	前竖搁条(左)	Pilaster	34620437	1.0/SUS201 油磨/454.5x55
47	食品架滑槽	Shelf Guide	34620406	δ 1.0x531x54/SUS201 2B
48	前竖搁条(右)	Pilaster	34620438	1.0/SUS201 油磨/454.5x55

49	后竖搁条(左)	Pilaster	34620439	1.0/SUS201 油磨/60x454.5
50	后竖搁条(右)	Pilaster	34620440	1.0/SUS201 油磨/60x454.5
51	小食品架	Shelf	W0402633	150x460 白色 浸塑 $\phi 7\phi 2.3$
52	食品架	Shelf	W0402367	A3/白色/浸塑/ $\phi 7/\phi 2.5/330\%x555$
53	箱体接口盖竖	Cabinet Frame	W041000082	硬质PVC/黑色/584mm/P92截面
54	箱体接口盖横	Cabinet Frame	W041000084	硬质PVC/黑色/860mm/P92截面
55	1.5ALED适配器预装图	Transformer	W0399177	输入电压: 100-240V/ $\sim 50/60\text{Hz}$ /输出电压: 24V(DC)/1.5A/36W/两边的线长均为250mm裸线
56	右门体开关(单刀双掷)	Door Switch	W0308012	HC-056K. 9R. 1/0.5A 250VAC /1.5A 125VAC
57	台面下梁	Under Counter Mullion	34620404	$\delta 1.5x1355x129$ /热镀锌板
58	两门台面板	Desktop	34621606	$\delta 0.7x1457.2x787.8$ /SUS304油磨
59	二门开关连接线(控蒸发风机)	Wire	W0303478	门开关控制蒸发风机用
60	调整脚	Leg	W0409018	不锈钢脚高150mm(120~180)/M14
61	机房右板	Right Plate	34620518	$\delta 0.5x652x718$ /SUS304油磨
62	机械室保护网	Protecting net	W0402659	长670 宽302 $\phi 2.3$ 黑色喷涂
63	冷凝器挡风罩	Condenser's wind cover	3,462E+09	组件