

WARING COMMERCIAL

Europe **TORq 2.0** Blender with 2 Toggle Switches **TBB145E**

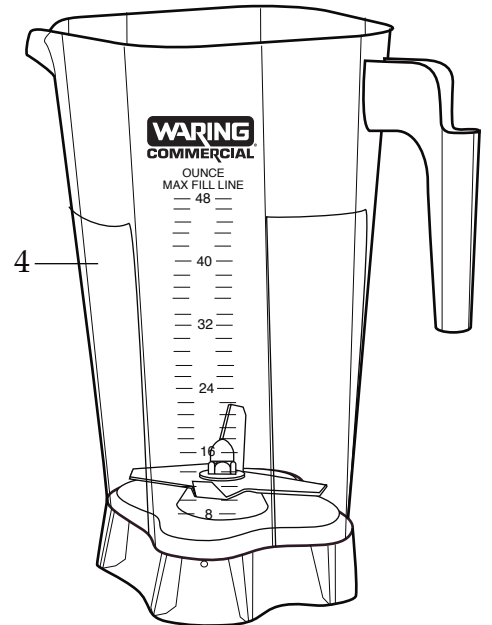

503482
Container with Blending Assembly

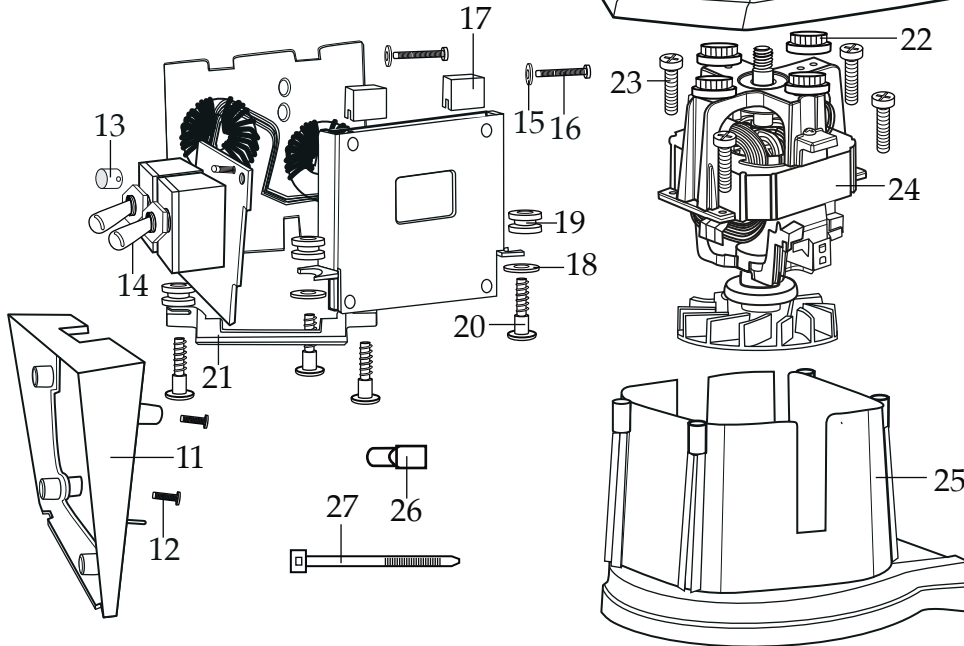
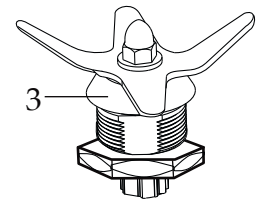
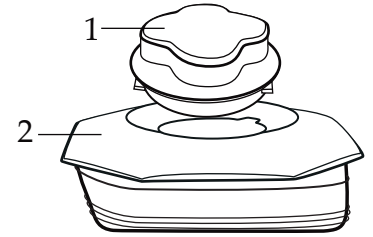
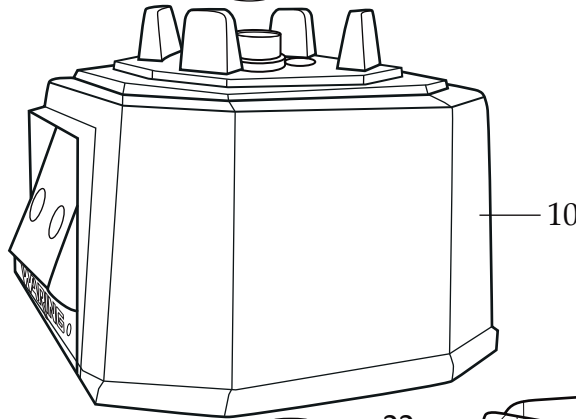
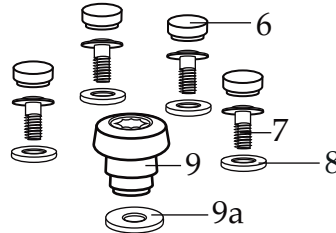
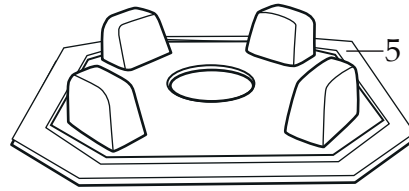
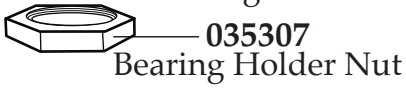
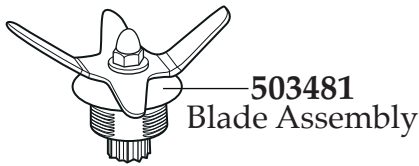
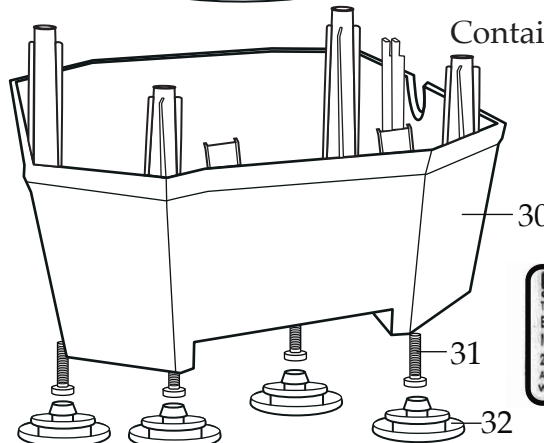
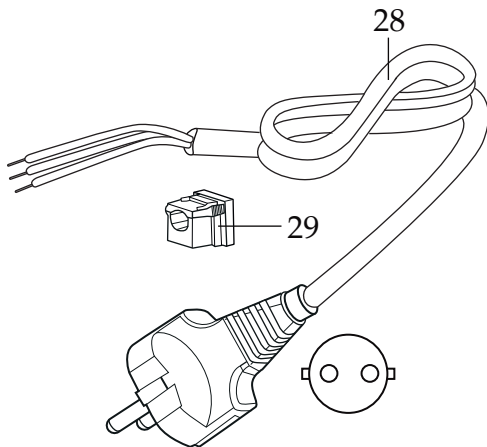

Date Code Location
YY|MM|DD
year year month month day day



| Illustration# | Part# | Description |
|---------------|------------------|---|
| 1 | 028769-E | Eastman Jar Lid Cover |
| 2 | 035238-V | Vinyl Jar Lid |
| 3 | 035465 | Blending Assembly Kit |
| 4 | 035239 | 48 oz. Stackable Container ONLY |
| 5 | 035885 035091 | Jar Pad (<i>changed after 7/6/2018</i>) Jar Pad (use 035885) |
| 6 | 035085 | Hole Plug (4 required) |
| 7 | 034275 | Sems (4 required) |
| 8 | 034273 | B Gasket (4 required) |
| 9 | 037034 035251 | Drive Goupling (<i>on units after 11/15/2019</i>) Drive Coupling |
| 9a | 037033 | Coupling Washer (<i>on units after 11/15/2019</i>) |
| 10 | 503460-145-E | Top Housing Assembly |
| 11 | 035083 | Control Housing Back Bezel |
| 12 | 035090 | Screw (2 required) |
| 13 | 035253 | LED Lens |
| 14 | 035163 | TBB145 230 volt Control Panel Assembly |
| 15 | 035255 | Washer (2 required) |
| 16 | 035089 | Screw (2 required) |
| 17 | 034900 | PCB Cushion (4 required <i>on units after 8/9/2018</i>) (2 required) |
| 18 | 013604 | Washer (4 required <i>on units after 8/9/2018</i>) (2 required) |
| 19 | 034904 | Rubber Grommet (4 required) |
| 20 | 034902 | Sems (4 required) |
| 21 | 035894 | Control Board Bracket |
| 22 | 034272 | A Gasket (4 required) |
| 23 | 034274 | Screw (4 required) |
| 24 | 035816 035475 | Chiaphua Motor No Sensor (<i>on units after 6/20/2018</i>) ECM Motor |
| 25 | 503483 | Motor Housing with Dampeners |
| 26 | 012409 019123 | Small Crimp Connectors (2 required) Large Crimp Connector (3 required) |
| 27 | 013731 | Cable Ties (6 required) |
| 28 | 017948 | Cordset |

Catalog/Model

TBB145E

Waring Factory Service Center
 314 Ella T. Grasso Ave.
 Torrington, CT 06790
 Tele. 1-800-269-6640

Waring
 COMMERCIAL

Fax 860-496-9017
 www.waringcommercialproducts.com

| Illustration# | Part# | Description |
|---------------|------------------|---|
| 29 | 033619 | Strain Relief |
| 30 | 503480 035079 | Bottom Housing Assembly with Feet Bottom Housing |
| 31 | 034274 | Screw (4 required) |
| 32 | 035088 | Foot (4 required) |

