

winterhalter



Spare parts list UC-M, UC-L, UC-XL

Drawn up: 14.04.09

Processed: 05.08.09

Parts no.:

Contents

Water inlet and tank heating	Page 1 - 2
Water softener	Page 3 - 4
Water drain, Mediamat Cyclo	Page 5 - 6
Circulating pump	Page 7 - 8
Wash + rinse; bottom	Page 9 - 10
Wash + rinse; top	Page 11 - 12
Boiler	Page 13 - 16
Dosage	Page 17 - 18
Panelling	Page 19 - 20
Cover plate, electrical parts	Page 21 - 22
Door	Page 23 - 24
Energy (Option)	Page 25 - 26
Hoses	Page 27 - 28
Accessories	Page 29 - 30

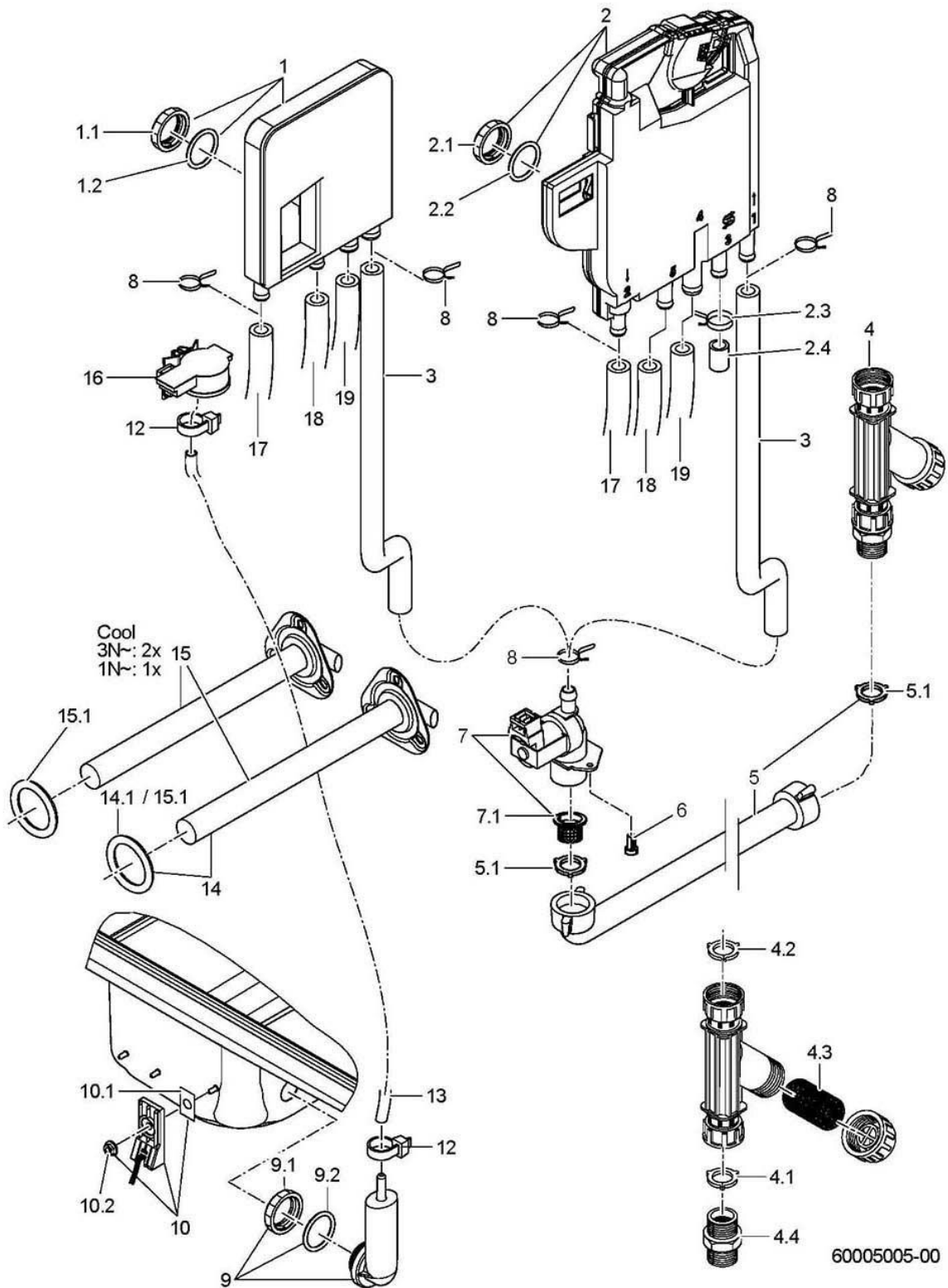

UC-M, UC-L, UC-XL

Water inlet and tank heating

Item.	Designation	Parts no.:	Pc.	Notes
1	Kit airflow preventer type "BPD"	30000128		
1.1	Nut; D26,2 X 8, SW32	60004612		
1.2	O-ring; 25,7 X 3	27 07 097		
2	Kit backflow preventer type "Air Gap"	30000127		
2.1	Nut; D26,2 X 8, SW32	60004612		
2.2	O-ring; 25,7 X 3	27 07 097		
2.3	Wire hose clamp; D14,4 X 15,1	28 02 344		
2.4	Locking cap; DN10 X 2,0 X 19	60004630		
3	Moulded hose; DN10 X 3,5 X 461	60004642		
4	Dirt trap; 150 µM	80002153		
4.1	Gasket; D16 X D24 X 3,0	80002241	3	
4.2	Strainer; D27 X 67 X 150µM	80002728		
4.3	Double nipple; G 3/4" X 40; SW30	80002167		
5	Water supply hose; DN13 X 3,5; 2500	40 02 060		
5.1	Gasket; D16 X D24 X 3,0	80002241	2	
6	Raised head screw; M4 X 8	20 10 310	2	
7	Solenoid valve flow restrictor 4l; 230-240V 50/60HZ RAST5	31 06 250		
7	Solenoid valve flow restrictor 4l; 200-240V/50-60HZ/+10%	31 06 251		Japan; Australia
7	Solenoid valve flow restrictor 3l; 200-240V/50-60HZ/+10%	31 06 211		Energy
7.1	Solenoid valve filter	31 06 186		
8	Wire hose clamp; D17,3 X 1,8	28 02 353		
9	Kit air chamber	30000114		
9.1	Nut; D26,2 X 8, SW32	60004612		
9.2	O-ring; 25,7 X 3	27 07 097		
10	Kit thermal sensor	30000126		
10.1	Heat conducting foil; 24 X 17 X 0,25MM	31 14 096		
10.2	Ratchet nut; M5	21 01 310		
12	Cable tie; 100 X 2,5	31 20 175		
13	Hose; DN5 X 1,5	40 01 024		930 mm; "By-the-metre" goods
14	Kit high power heating cartridge 1.8KW	30000122		
14.1	O-ring; 34 X 6,0	27 07 092		
15	Kit high power heating cartridge 2.5KW	30000123		UC-x Cool
15.1	O-ring; 34 X 6,0	27 07 092		
16	Pressure transmitter; 0-30MBAR;5VDC/0,5-3,5V	31 26 044		
17				See page 27-28
18	Moulded hose; DN13 X 2,0	60004668		
19	Moulded hose; DN10 X DN13 X 2,0	60004664		

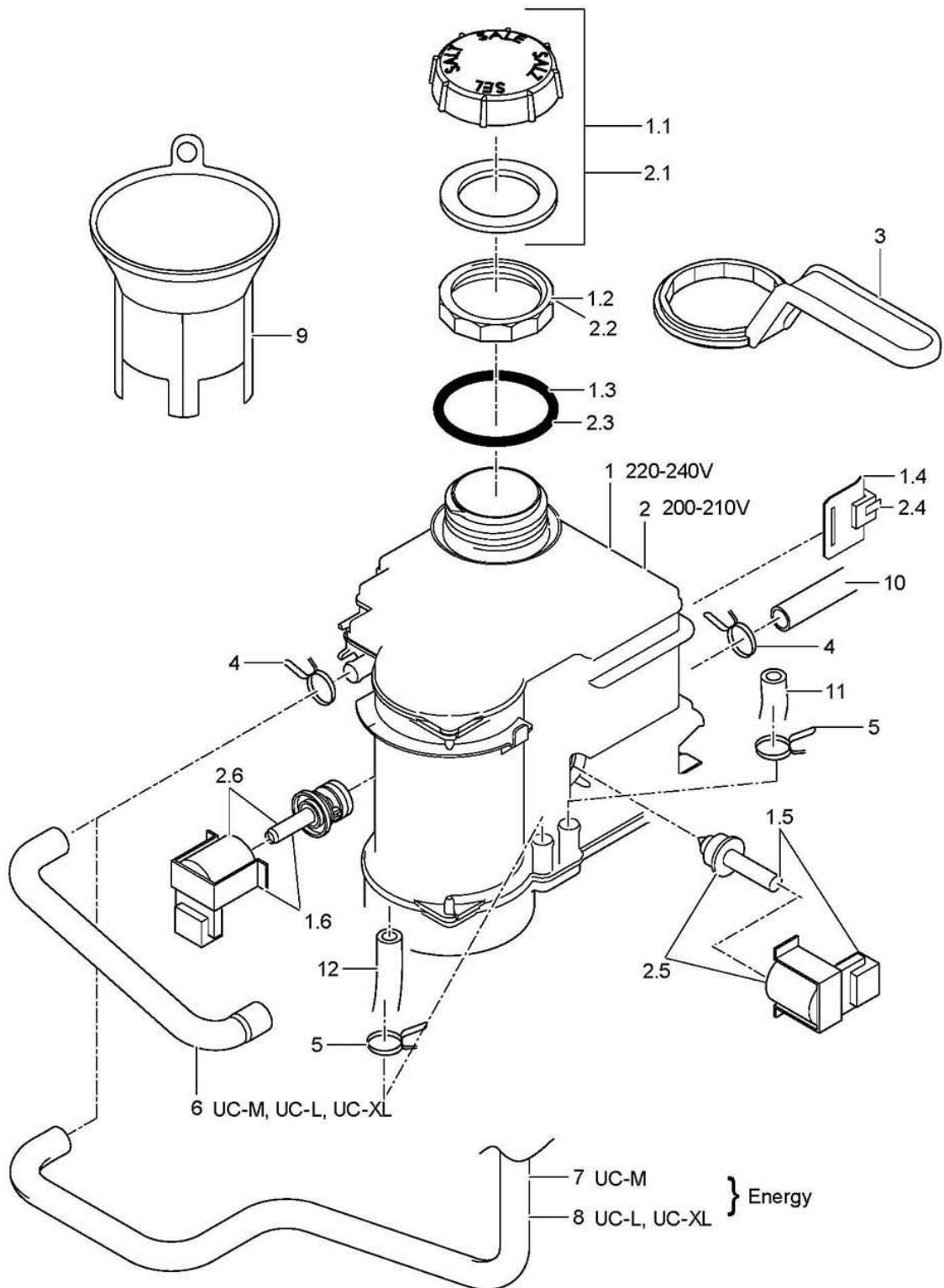

60005006-00

UC-M, UC-L, UC-XL

Water softener

Item.	Designation	Parts no.:	Pc.	Notes
1	Water softener kit; 220-240V; 50/60HZ	83000420		
1.1	Salt container cover with gasket	83000496		
1.2	Lock nut; S54 X 4; D56	60003001		
1.3	O-ring; 54 X 5	27 07 065		
1.4	Dry reed contact lack of salt	83000408		
1.5	Repair kit regeneration valve; 220-240V,50/60HZ	83000402		
1.6	Repair kit reversing valve; 220-240V,50/60HZ	83000460		
2	Water softener kit; 200-210V; 50/60HZ	83000421		
2.1	Salt container cover with gasket	83000496		
2.2	Lock nut; S54 X 4; D56	60003001		
2.3	O-ring; 54 X 5	27 07 065		
2.4	Dry reed contact lack of salt	83000408		
2.5	Repair kit regeneration valve; 200-210V,50/60HZ	83000463		
2.6	Repair kit reversing valve; 200-210V,50/60HZ	83000467		
3	Double hex ring spanner; SW61,5	60003376		
4	Wire hose clamp; D16,4 X 1,8	28 02 352	2	
5	Wire hose clamp; D14,4 X 15,1	28 02 344	2	
6	Moulded hose; DN10 X DN11 X 2,0	60004671		
7	Moulded hose; DN10 X 2,0	60004683		UC-M Energy
8	Moulded hose; DN10 X 2,0	60004672		UC-L Energy, UC-XL Energy
9	Filling funnel	35 02 013		
10	Moulded hose; DN10 X 2,0	60004711		
11	Hose; DN10 X 2,0	40 01 050		800 mm; "By-the-metre" goods
12	Hose; DN10 X 2,0	40 01 050		650 mm; "By-the-metre" goods

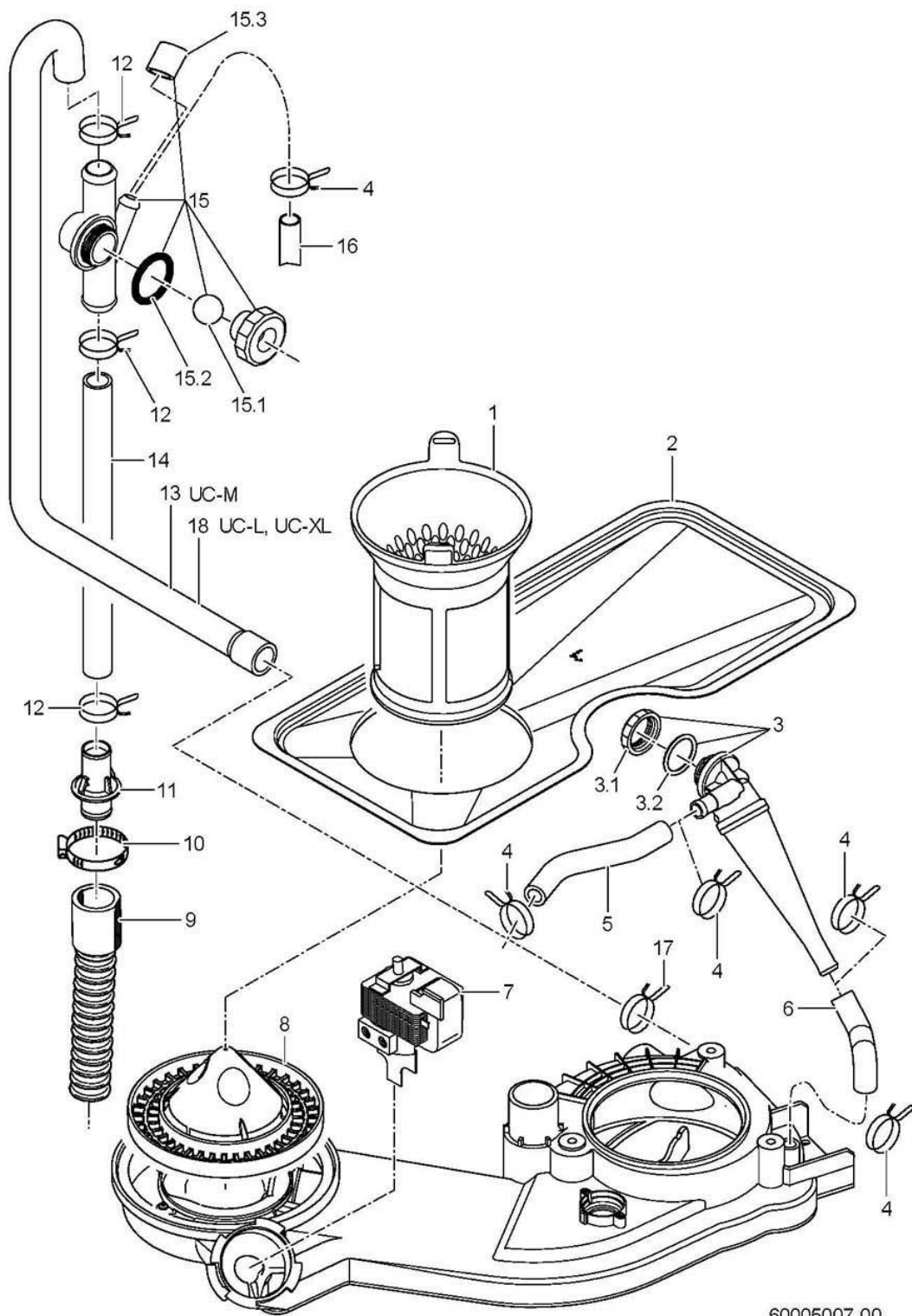

60005007-00

UC-M, UC-L, UC-XL

Water drain, Mediamat Cyclo

Item.	Designation	Parts no.:	Pc.	Notes
1	FILTER CYLINDER	60004463		
2	Flat filter; 1,0 X 238 X 540,95	60004357		
3	Kit Mediamat	30000113		
3.1	Nut; D26,2 X 8, SW32	60004612		
3.2	O-ring; 25,7 X 3	27 07 097		
4	Wire hose clamp; D17,3 X 1,8	28 02 353		
5	Hose; DN10,5 X 3,0; 139	60004628		
6	Moulded hose; DN12,5 X 2,00	60004620		
7	Drain pump; 220-240V/50HZ	31 02 480		
7	Drain pump; 200V/50HZ;220-240V/60H	31 02 493		
7	Drain pump; 200V/60HZ	31 02 495		
8	FILTER BOTTOM; D139 X 63,5	60004466		
9	Drain hose; 1500 LG	60003738		
10	Hose clamp; D20-30 X 12	28 02 109		
11	Double nipple; D21,8 X 55, D20,8	60004609		
12	Wire hose clamp; D24,2 X 2,2	28 02 358		
13	Shaped hose; DN18 X DN22; 814	60003281		UC-M
14	Reinforced hose; DN19 X 2,5	40 01 046		460 mm; "By-the-metre" goods
15	Deaeration kit	60003514		
15.1	Ball; D14	28 01 508		
15.2	O-ring; 24 X 3,0	27 07 087		
15.3	Round cap; D11 X 20	35 03 029		
16	Moulded hose; DN10 X 2,0	60004711		from built-in water softener
17	Wire hose clamp; D30 X 2,8	30000212		
18	Shaped hose; DN18 X DN22 X 2,25	60004004		UC-L; UC-XL

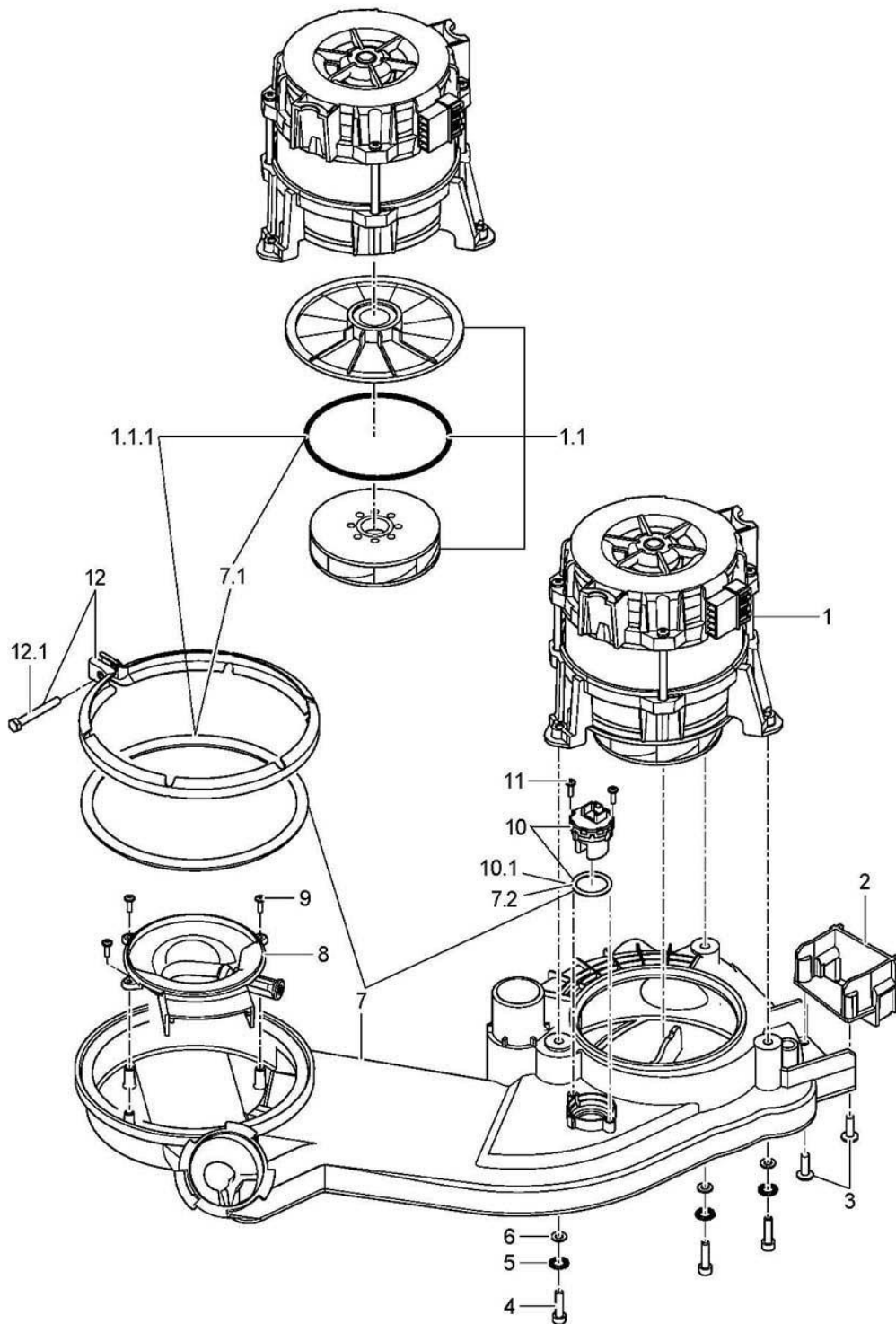

60005008-00

UC-M, UC-L, UC-XL

Circulating pump

Item.	Designation	Parts no.:	Pc.	Notes
1	KIT CIRCULATING PUMP	30000167		
1.1	Impeller with sealings kit; D92	60003592		
1.1.1	Sealing for pump system kit	60003591		
2	Adapter bracket	60004710		
3	PT screw; KB 50 X 16	20 17 007	2	
4	Cylinder head screw; M5 X 20; 8,8	20 09 337	3	
5	Serrated lock washer; A-5,3	22 02 316	3	
6	Washer; D5,3 X D10 X 1,0	22 01 300	3	
7	Kit COLLECTOR	30000169		
7.1	Sealing for pump system kit	60003591		
7.2	O-ring; 21 X 3	27 07 096		
8	SUCTION CHANNEL	60004467		
9	PT screw; KB 30 X 10	20 17 005	3	
10	KIT DIFFUSION SENSOR	30000168		
10.1	O-ring; 21 X 3	27 07 096		
11	PT screw; KB 30 X 10	20 17 005	2	
12	Pump clip	62003437		
12.1	Hexagon screw; M5 X 40; A70	20 01 329		

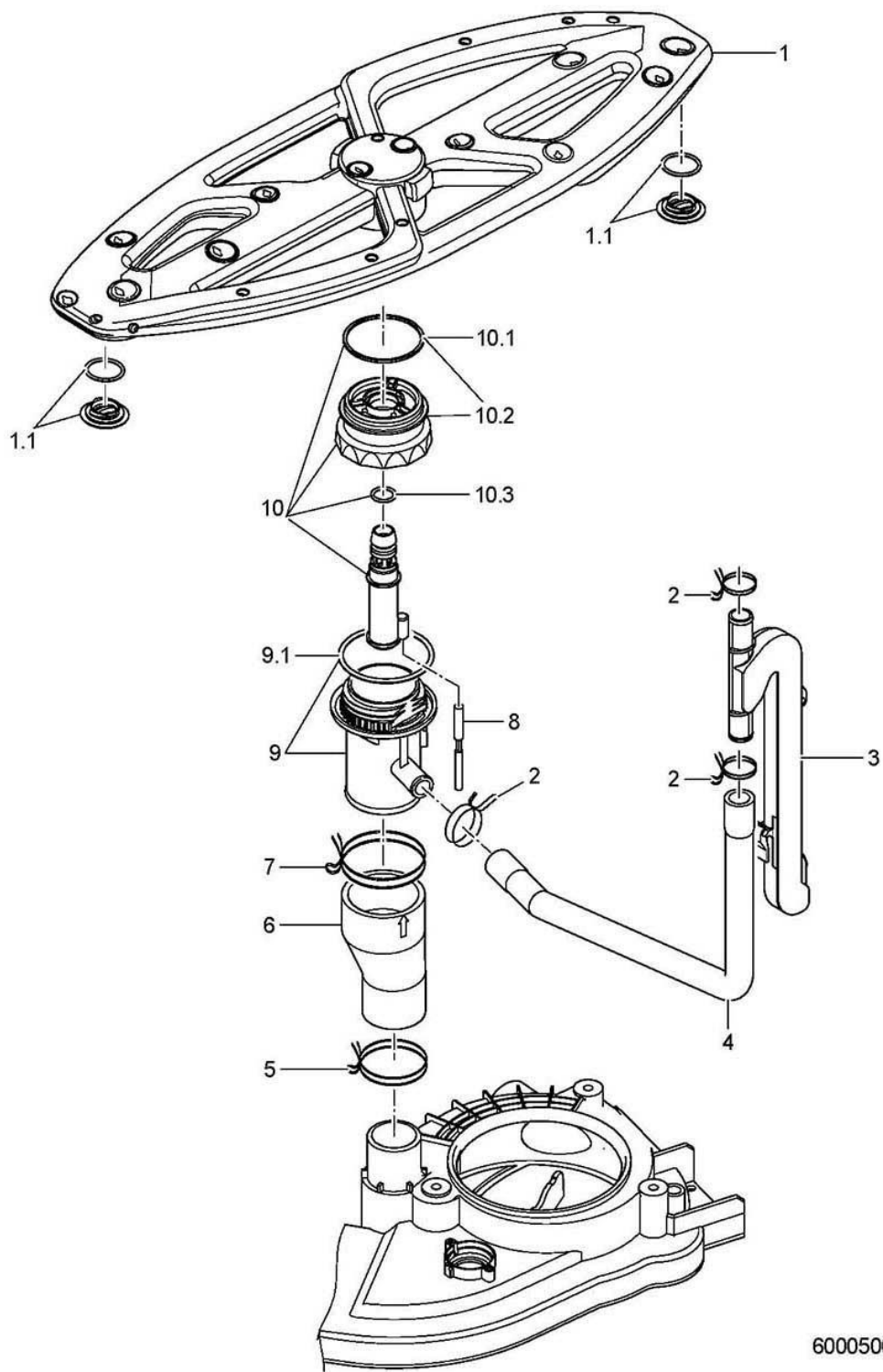

6005009-00

UC-M, UC-L, UC-XL

Wash + rinse; bottom

Item.	Designation	Parts no.:	Pc.	Notes
1	Wash field	60004427		
1.1	Plug	60004854	2	
2	Wire hose clamp; D21,2 X 2	28 02 355		
3	Rinse manifold	60004611		
4	Moulded hose bottom; DN13,5 X 3,0 X 370	60004625		
5	Wire hose clamp; D44,4 X 3,2	28 02 367		
6	Reducing hose; DN33 X DN46; 97	60004591		
7	Wire hose clamp; D56 X 3,5	28 02 371		
8	Magnetic switch; 25,5 X D5,8; 220MM LG	31 24 297		
9	KIT WATER INLET BOTTOM	30000199		
9.1	O-ring; 56 X 3,0	27 07 086		
10	Kit wash field take-up device bottom	30000112		
10.1	Seal ring; D48,4 X 52,5 X 1,6	60004430		
10.2	Lock nut bottom	60004872		
10.3	O-ring; 13 X 2	30000251		

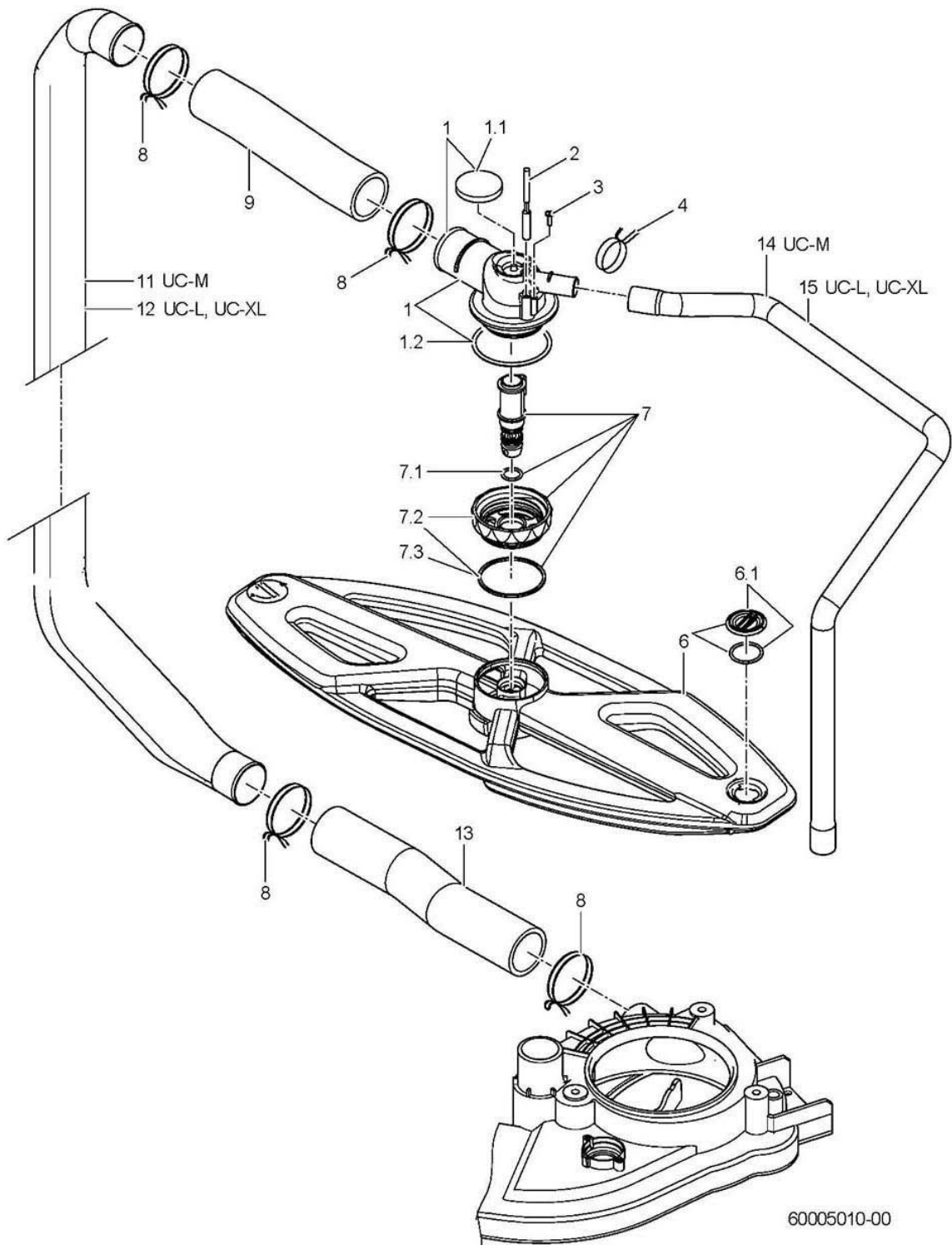

UC-M, UC-L, UC-XL

Wash + rinse; top

Item.	Designation	Parts no.:	Pc.	Notes
1	KIT WATER INLET TOP	30000200		
1.1	FOAM RUBBER	60004500		
1.2	O-ring; 56 X 3,0	27 07 086		
2	Magnetic switch; 25,5 X D5,8; 220MM LG	31 24 297		
3	PT screw; KB 30 X 10	20 17 005		
4	Wire hose clamp; D21,2 X 2	28 02 355		
6	Wash field	60004427		
6.1	Plug	60004854	2	
7	Kit wash field take-up device top	30000111		
7.1	O-ring; 13 X 2	30000251		
7.2	Lock nut top	60004870		
7.3	Seal ring; D48,4 X 52,5 X 1,6	60004430		
8	Wire hose clamp; D44,4 X 3,2	28 02 367		
9	Hose; DN33 X 4,0; 225	60004843		adapt
11	RISER	60004572		UC-M
12	RISER	60004514		UC-L; UC-XL
13	Hose; DN33 X 4,0; 225	60004843		
14	Moulded hose top; DN13,5 X 3,0 X 605	60004644		UC-M
15	Moulded hose top; DN13,5 X 3,0 X 700	60004624		UC-L; UC-XL

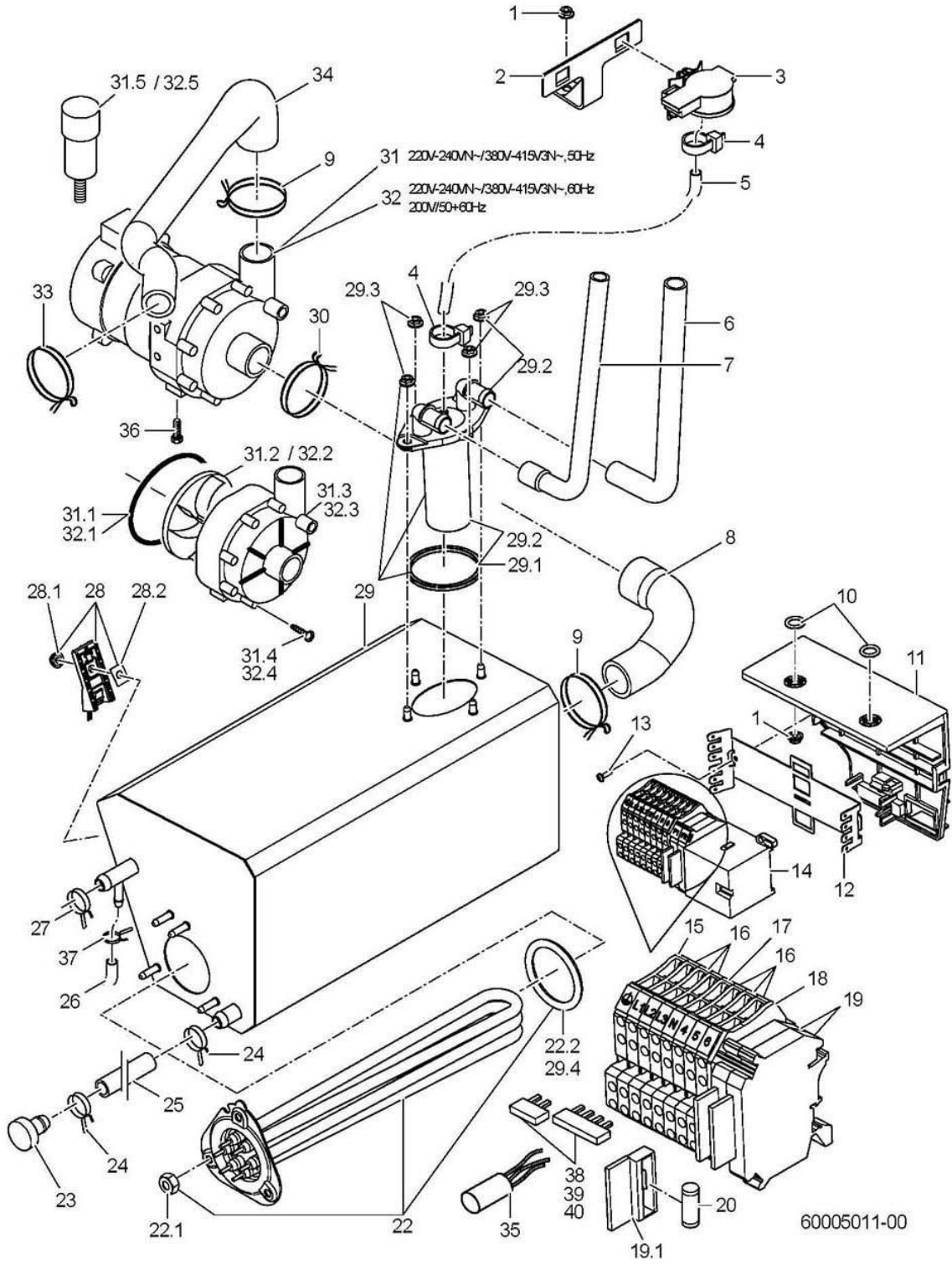

UC-M, UC-L, UC-XL

Boiler

Item.	Designation	Parts no.:	Pc.	Notes
1	Ratchet nut; M5	21 01 310		
2	Retainer; 53,62 X 104	60004493		
3	Pressure transmitter; 0-30MBAR;5VDC/0,5-3,5V	31 26 044		
4	Cable tie; 100 X 2,5	31 20 175		
5	Hose; DN5 X 1,5	40 01 024		650 mm; "By-the-metre" goods
6	Moulded hose; DN13 X 2,0	60004667		
7	Moulded hose; DN10 X DN13 X 2,0	60004664		
8	Moulded hose; DN23,5 X DN26,5 X 3,5	60004573		
9	Wire hose clamp; D32,7 X 2,8	28 02 362		
10	O-ring; 10 X 2,5	27 07 030	2	
11	Housing; 62 X 121 X 139	60004821		
12	Assembly plate; 0,8 X 61,2 X 175,26	60004819		
13	PT screw; KB 30 X 10	20 17 005		
14	Contacteur B7:3H 1 N/C contact; 220-255V/50-60HZ	31 04 154		
14	Contacteur B7:3H 1 N/C contact; 200V/50-60HZ	31 04 171		Japan
15	UT 4-Quattro, potencial earth, double terminal; GRÜN/GELB	31 09 272		
16	UT 4-Quattro double terminal; GRAU	31 09 270	6	
17	Blue UT 4-Quattro, double terminal; BLAU	31 09 271		
18	Cover; D-UT 2,5/4-QUATTRO	31 09 279		
19	Universal fuse clip	31 09 063	2	
19.1	Securing plug	31 09 072		
20	Fine fuse, medium time lag; 250V; 4,0A; 5 X 20	31 11 123		
22	Kit heating element 4.9KW with fuse	30000125		
22	Kit heating element 6.5KW with fuse	30000124		Japan; Australia
22.1	Hexagonal nut; M5	21 01 203	3	
22.2	O-ring; 46 X 6,0	27 07 085		
23	Plug; D24 X D13,1 X 27	70007962		
24	Wire hose clamp; D14,4 X 15,1	28 02 344		
25	Hose; D10 X 2	40 02 034		450 mm; "By-the-metre" goods
26	Hose; DN5 X 1,5	40 01 027		510 mm; "By-the-metre" goods
27	Wire hose clamp; D17,3 X 1,8	28 02 353		
28	Kit thermal sensor	30000126		
28.1	Ratchet nut; M5	21 01 310		
28.2	Heat conducting foil; 24 X 17 X 0,25MM	31 14 096		
29	Kit boiler	30000119		
29.1	Four-lipped seal; D50,39 X 3,53	30000134		
29.2	Kit air chamber, boiler	30000116		
29.3	Ratchet nut; M5	21 01 310	4	
29.4	O-ring; 46 X 6,0	27 07 085		
30	Wire hose clamp; D35 X 3	28 02 364		

For missing items, see next page

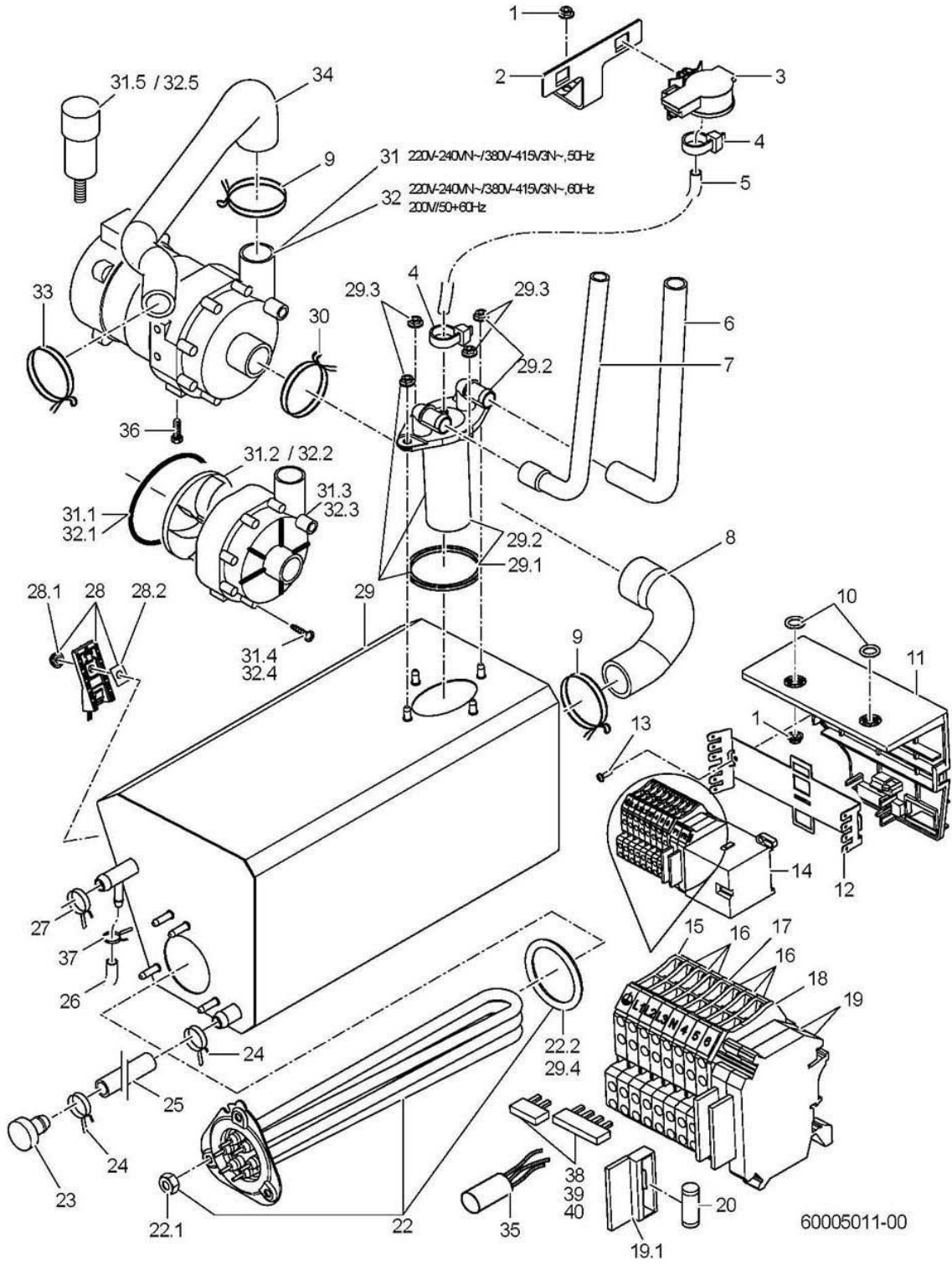

UC-M, UC-L, UC-XL

Boiler

Item.	Designation	Parts no.:	Pc.	Notes
31	Pump 0.14kW 3/3; 220V/240V/1/50HZ	31 02 561		220V-240VN~/380V-415V3N~,50Hz
31.1	Cord; D=78 X 3; SHOR 50-55;	40 04 023		
31.2	Pump impeller; FÜR UP60/UP30 MIT 50HZ	31 02 466		
31.3	Pump housing; D=80,5MM	31 02 519		
31.4	Screw for pump housing	31 01 118	7	
31.5	Capacitor; 4 MIKRO F / 400V	31 13 171		
32	Pump 0.20kW 3/3; 200-240V/1/50-60HZ	31 02 589		220V-240VN~/380V-415V3N~,60Hz; 200V/50+60Hz
32.1	Cord; D=78 X 3; SHOR 50-55;	40 04 023		
32.2	Pump impeller, installed; FÜR UP60 MIT 60HZ	31 02 587		
32.3	Pump housing; D=80,5MM	31 02 519		
32.4	Screw for pump housing	31 01 118	7	
32.5	Capacitor; 5 MIKRO F	31 13 099		
33	Wire hose clamp; D26,8 X 2,5	28 02 360		
34	Moulded hose; DN18 X DN24 X 3,5	60004632		
35	Radio interference suppression capacitor; 0,22 MF + 2 X 22'000PF	31 13 211		
36	Hexagon screw; M5 X 16; A70	20 01 309		
37	Wire hose clamp; D8,6 X 1	28 02 348		
38	Fixed bridge kit	60004858		220V-240VN~/380V-415V3N~,50+60Hz
39	Fixed bridge kit	60004859		230V/3/PE/50Hz + 60Hz
40	Fixed bridge kit, Japan	60004860		200V2~/200V3~,50+60Hz

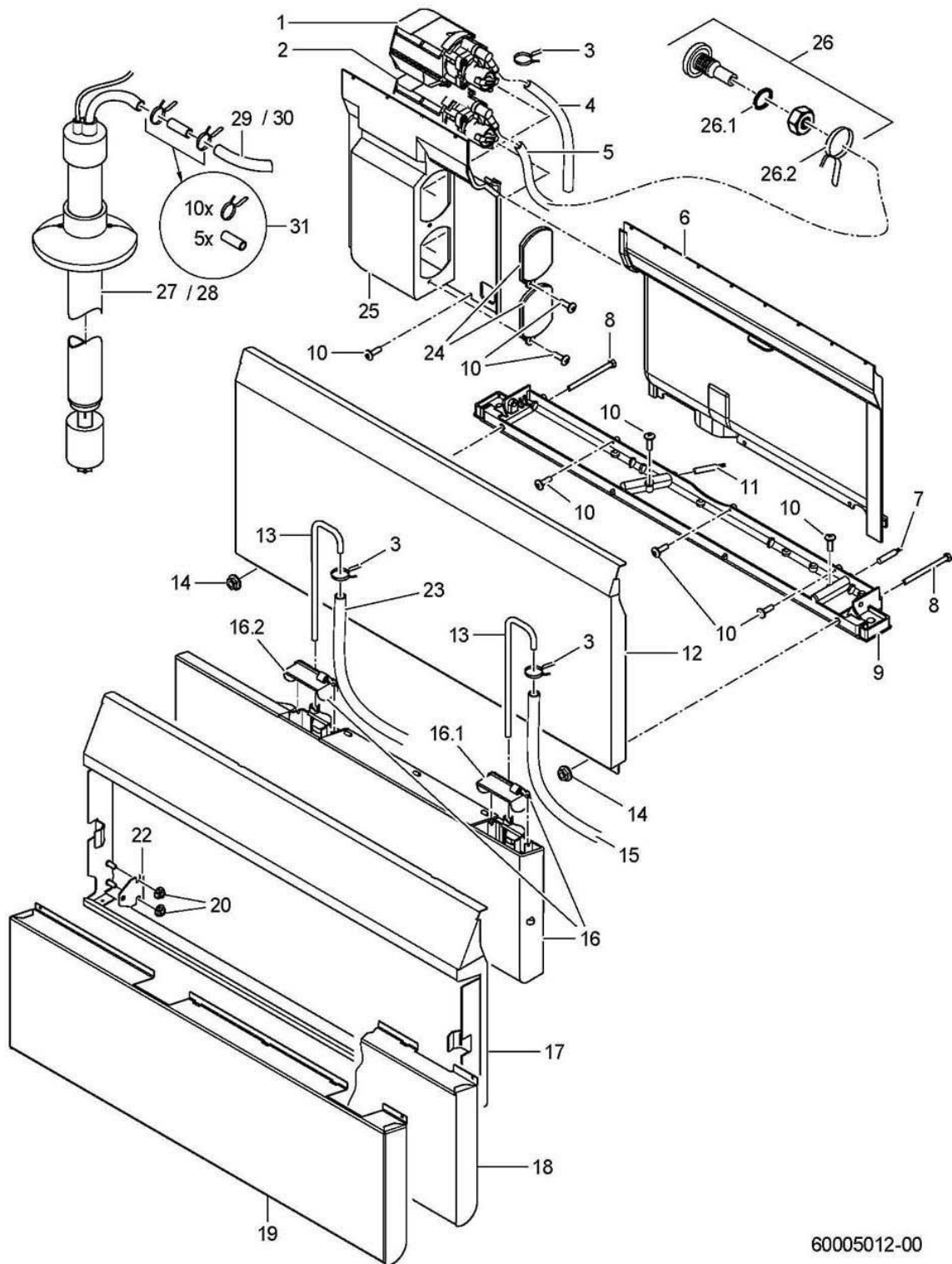

UC-M, UC-L, UC-XL

Dosage

Item.	Designation	Parts no.:	Pc.	Notes
1	Fluidos DB "Rinse aid" kit; 115-240V/50-60HZ	31 02 598		
2	Fluidos DT "Detergent" kit; 115-240V/50-60HZ	31 02 597		
3	Wire hose clamp; D8,6 X 1	28 02 348		
4	Hose; DN5 X 1,5	40 01 027		510 mm; "By-the-metre" goods
5	Hose; DN5 X 1,5	40 01 024		370 mm; "By-the-metre" goods
6	SEPARATING PLATE RIGHT	60004534		
7	Magnetic switch; 25,5 X D5,8; 220MM LG	31 24 297		
8	Hexagon screw; M5 X 65	20 01 206	2	
9	TRANSVERSE GIRDER	60004532		
10	PT screw; KB 30 X 10	20 17 005		
11	Magnetic switch; 25,5 X D5,8; 450MM LG	31 24 296		
12	Kit service flap 15 M; L; XL	30000256		without detergent, freshwater rinse dispenser
13	SUCTION TUBE; D6 X 1,0 X 209	60004729		
14	Ratchet nut; M5	21 01 310	2	
15	Hose; DN5 X 1,5	40 01 027		570mm; "By-the-metre" goods
16	Kit chemical container big	30000117		
16.1	FLAP BLUE; 30,2 X 32,8 X 59,8	60004540		
16.2	FLAP WHITE; 30,2 X 32,8 X 59,8	60004541		
17	SERVICE FLAP 35	60004659		
18	Panelling	60004814		only dosing of rinse aid or detergent
19	Panelling	60004657		with detergent, freshwater rinse dispenser
20	Ratchet nut; M5	21 01 310	4	
22	Sheet metal; 1,25 X 35 X 36	60004662	2	
23	Hose; DN5 X 1,5	40 01 024		270 mm; "By-the-metre" goods
24	Cover	60004588		
25	SEPARATING PLATE LEFT	60004533		
26	Dosing nipple set; M10 X 29; SW5	61005883		
26.1	O-ring; 10 X 2,5	27 07 030		
26.2	Wire hose clamp; D8,6 X 1	28 02 348		
27	Suction tube SD 425 kit for detergent	30000010		
28	Suction tube SD 425 kit for rinse aid	30000011		
29	Hose; DN5 X 1,5	40 01 024		1000 mm; "By-the-metre" goods
30	Hose; DN5 X 1,5	40 01 027		1000 mm; "By-the-metre" goods
31	Dosing tube connection kit (5 pc.)	30000012		

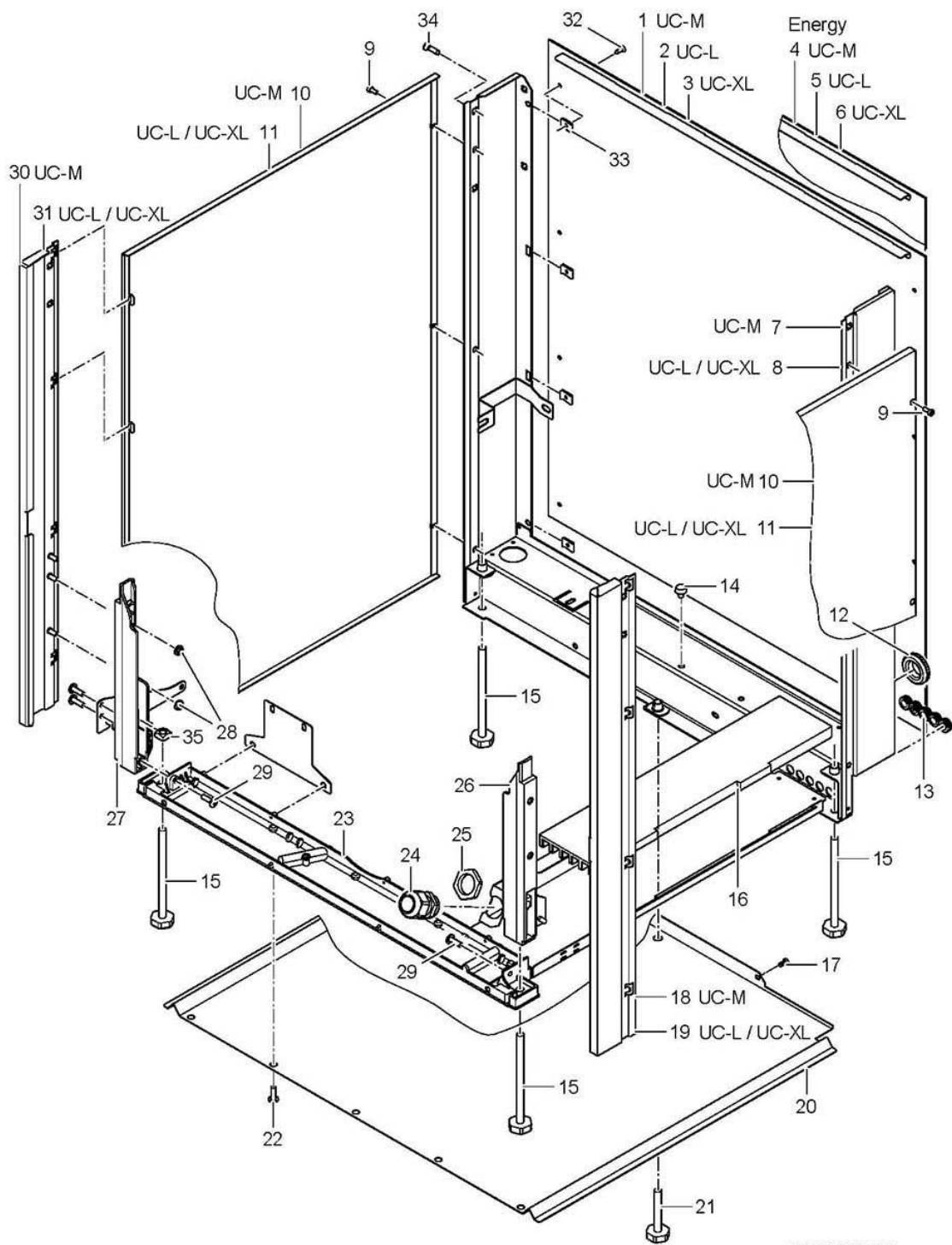

60005013-00

UC-M, UC-L, UC-XL

Panelling

Item.	Designation	Parts no.:	Pc.	Notes
1	Back panel	62003846		UC-M; Stainless steel
1	Back panel	62003931		UC-M; Plastic
2	Back panel	60004461		UC-L; Stainless steel
2	Back panel	60004852		UC-L; Plastic
3	Back panel	60004922		UC-XL; Stainless steel
4	Back panel	62003856		UC-M Energy; Stainless steel
4	Back panel	62003961		UC-M Energy; Plastic
5	Back panel	60004714		UC-L Energy; Stainless steel
5	Back panel	60004855		UC-L Energy; Plastic
6	Back panel	60004925		UC-XL Energy; Stainless steel
7	Base frame, rear	62003719		UC-M
8	Base frame, rear	60004402		UC-L; UC-XL
9	Cylinder head screw (Hexagon socket); M4 X 9,5	60004873	6	
10	Kit side panelling S; M	30000258	2	UC-M
11	Kit side panelling L; XL	30000255	2	UC-L; UC-XL
12	Sleeve; 9,0 X D36; D20	61006576		
13	Hose nozzle; 6,25 X D15; D8,5	61004890	5	
14	Buffer; D8 X 14	40 06 023		
15	Adjustable foot; M8 X 129; SW24	60004274	4	
16	INSERT; 15,5 X 88 X 380	60004610		
17	Raised head screw; M4 X 8	20 10 310	2	
18	FOOT REST FRONT RIGHT	62003717		UC-M
19	FOOT REST FRONT RIGHT	60004593		UC-L; UC-XL
20	Kit floor panel M; L; XL	30000257		
21	Adjustable foot; M8 X 59; SW24	62003652		
22	PT screw; KB 50 X 12	20 17 009	5	
23	TRANSVERSE GIRDER	60004532		
24	Cable gland; M25 X 1,5;9-17MM;IP68	31 10 153		
25	Hexagonal nut; M25 X 1,5 X 6,0; SW32	31 10 163		
26	FOOT RIGHT	60004531		
27	FOOT LEFT	60004530		
28	Ratchet nut; M5	21 01 310	4	
29	PT screw; KB 50 X 16	20 17 007	2	
30	FOOT REST FRONT LEFT	62003716		UC-M
31	FOOT REST FRONT LEFT	60004592		UC-L; UC-XL
32	Sheet metal screw; ST 3,9 X 13	20 20 310	10	
33	Sheet metal nut; B 3,9	21 17 301	10	
34	PT screw; KB 50 X 20	20 17 008		
35	Square nut; M8	21 08 002	2	

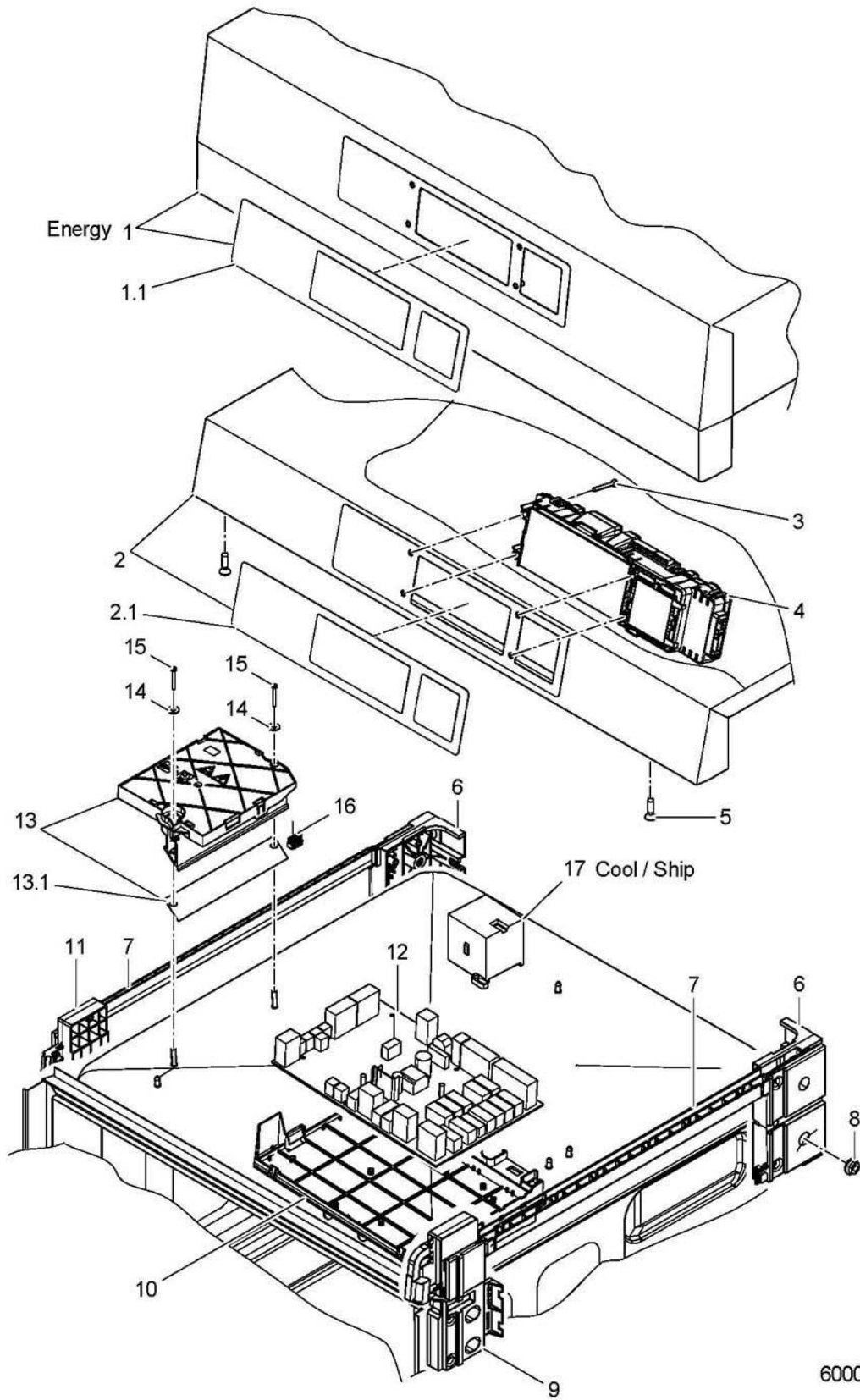

60005014-00

UC-M, UC-L, UC-XL

Cover plate, electrical parts

Item.	Designation	Parts no.:	Pc.	Notes
1	Cover plate	30000195		UC-x Energy
1.1	OPERATING FOIL; 0,175 X 60 X 268,5	31 24 291		
2	Cover plate	30000194		
2.1	OPERATING FOIL; 0,175 X 60 X 268,5	31 24 291		
3	Countersunk screw, M3 X 25	20 10 023	4	
4	Kit programme control Master	30000181		
5	PT screw, KB 50 X 20	20 17 008	2	
6	Support corner rear; 60 X 89 X 149,5	60004525	2	
7	Guide profile; 439,5 LG	60004526	2	
8	Ratchet nut; M5	21 01 310		
9	Support corner front right; 51,4 X 119,4 X 163,6	60004523		
10	Assembly plate; 61,1 X 223,9 X 272,4	60004522		
11	Support corner left; 36,5 X 97,2 X 163,6	60004524		
12	Kit programme control Slave	30000170		
13	Kit frequency inverter	30000121		
13.1	Heat conducting foil; 0,5 X 39 X 163 MM	60004641		
14	Washer; D4,3 X D12 X 1,0	22 05 300	2	
15	Countersunk screw, M3 X 25	20 10 023	2	
16	BUS CABLE UC-S/M/L/XL; 0,35QMM; 980 LG	60004690		
17	Contacteur B7:3H 1 N/C contact; 220-255V/50-60HZ	31 04 154		UC-x Cool

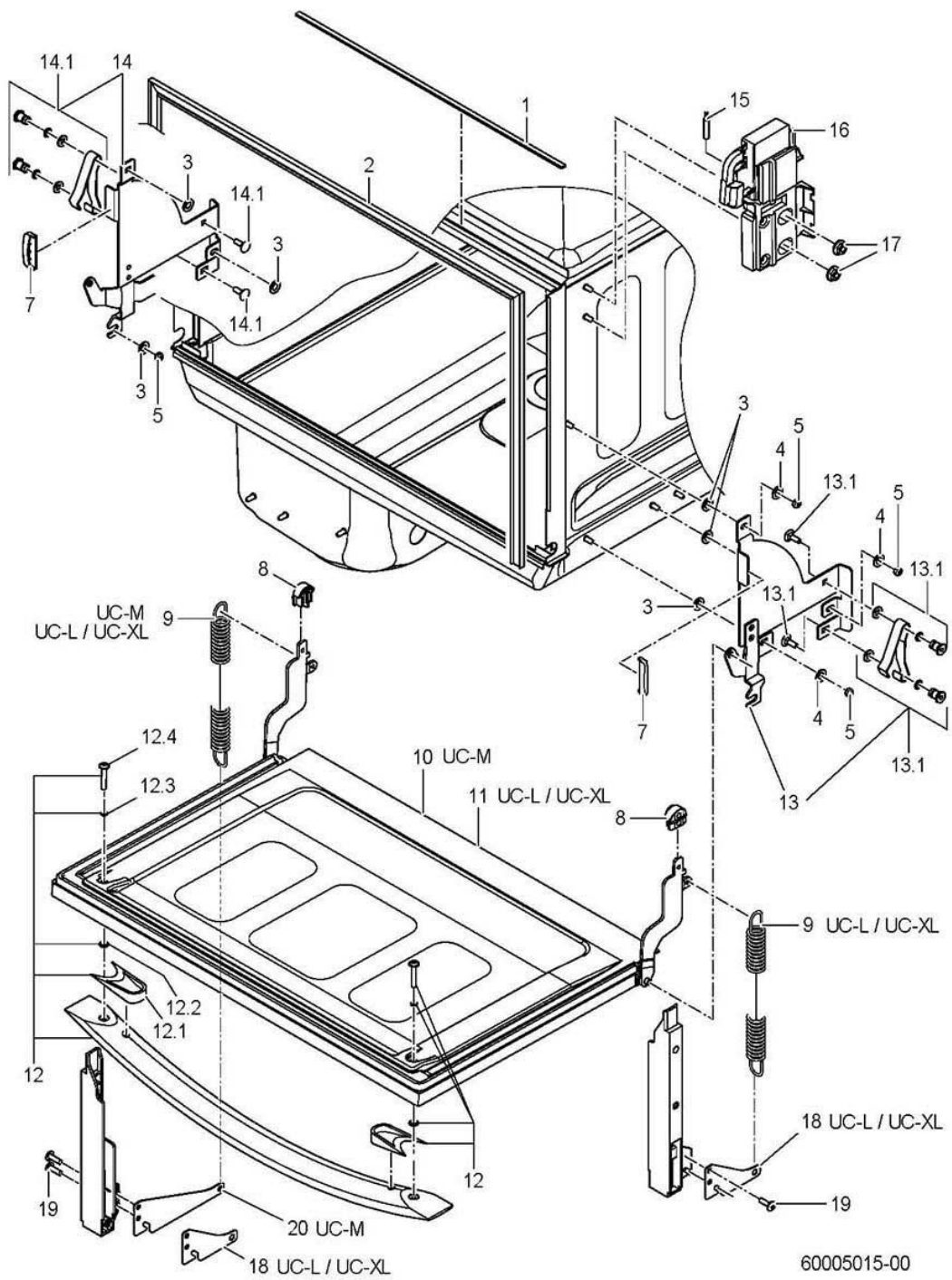

UC-M, UC-L, UC-XL

Door

Item.	Designation	Parts no.:	Pc.	Notes
1	Adhesive tape; 9 BREIT;2 DICK X 10000	48 03 022		1 roll = 10 m
2	Door seal; 463,7 X 575,9	60004475		
3	Washer; D5,3 X D15 X 1,2	22 05 301		
4	Washer; D5,3 X D10 X 1,0	22 01 300		
5	Hexagonal nut; M5 SELBSTSICHERND	21 05 302		
7	Buffer; 7,93 X 14 X 44,2	60004950	2	
8	Sliding roller; 10,5 X 22,5 X 25	60004595	2	
9	Tension spring; L0=193;L1=360;F1=82	60003697		
10	Door cpl.	60004566		UC-M
11	Door cpl.	60004346		UC-L; UC-XL
12	Kit door handle	30000129		
12.1	Spacing piece; 14 X 33,9 X 63,3	60004685	2	
12.2	O-ring; 6 X 2	27 07 012	2	
12.3	O-ring; 5 X 1,2	27 07 070	2	
12.4	Oval head screw with hexagonal socket; M5 X 30 MIT FLANSCH	20 10 308	2	
13	Basic panel, right	60004339		
13.1	Leaf spring repair kit	60003998		
14	Basic panel, left	60004412		
14.1	Leaf spring repair kit	60003998		
15	Magnetic switch; 25,5 X D5,8;720MM LG	31 24 295		
16	Support corner front right; 51,4 X 119,4 X 163,6	60004523		
17	Ratchet nut; M5	21 01 310	2	
18	SPRING HOLDER; 1,25 X 50 X 84	60004515	2	UC-L; UC-XL
19	PT screw, KB 50 X 16	20 17 007		
20	SPRING HOLDER (M); 1,5 X 51 X 138,5	60004841		UC-M

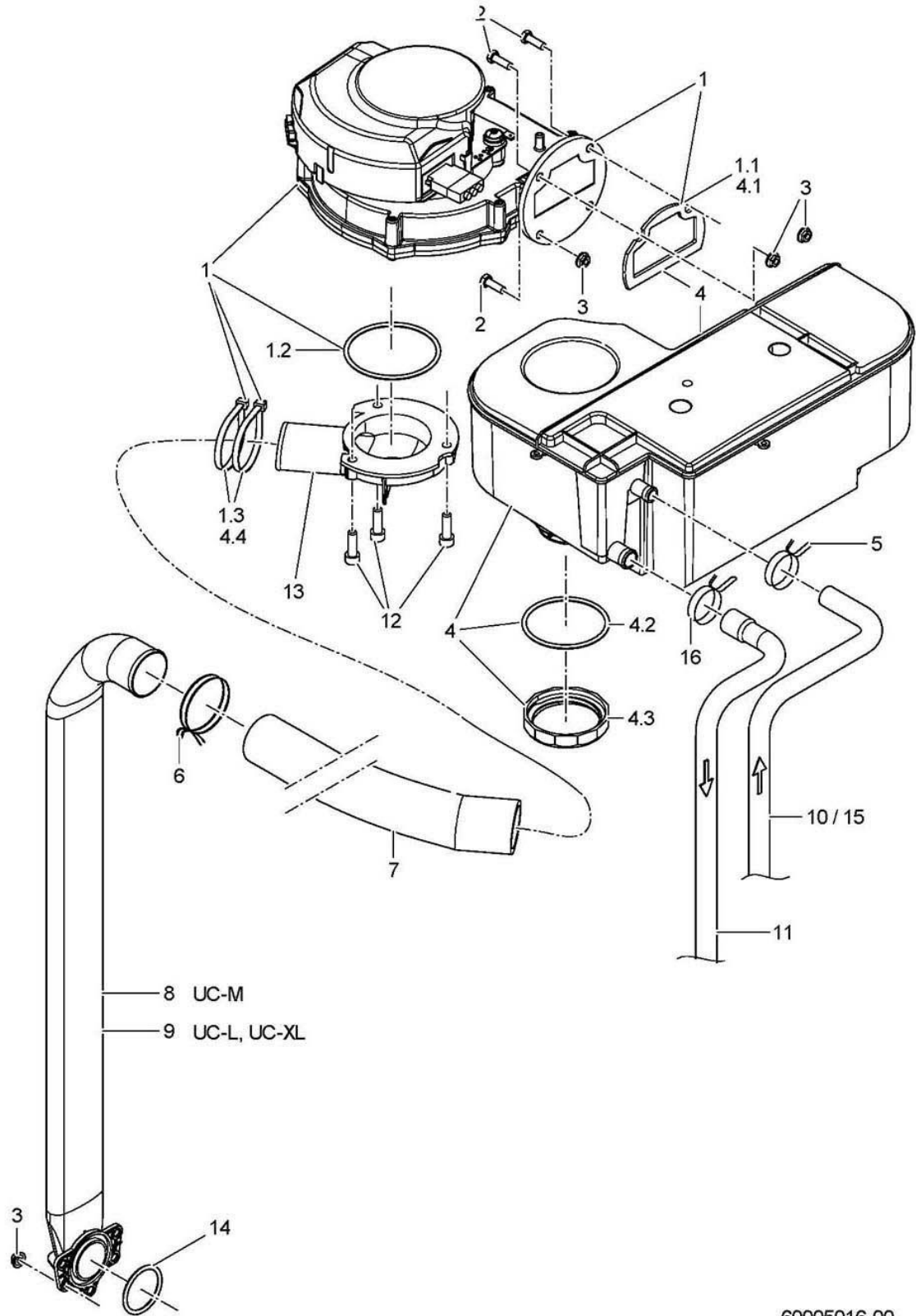

60005016-00

UC-M, UC-L, UC-XL**Energy (Option)**

Item.	Designation	Parts no.:	Pc.	Notes
1	KIT RADIAL FAN	30000189		
1.1	SEAL FAN; 51,8 X 79,4 X 2,5	60004606		
1.2	O-ring; 62,5 X 3	27 07 098		
1.3	Cable tie; 200 X 4,7	31 20 015	2	
2	Hexagon screw; M5 X 16; A70	20 01 309	4	
3	Ratchet nut; M5	21 01 310		
4	Kit HEAT EXCHANGER	30000190		
4.1	SEAL FAN; 51,8 X 79,4 X 2,5	60004606		
4.2	O-ring; 56 X 3,0	27 07 086		
4.3	Lock nut; S54 X 4; D56	60003001		
4.4	Cable tie; 200 X 4,7	31 20 015	2	
5	Wire hose clamp; D16,4 X 1,8	28 02 352		
6	Wire hose clamp; D40,5 X 3,2	28 02 365		
7	Moulded hose; DN33 X 2,0	60004517		
8	Riser vapour	62003778		UC-M
9	Riser vapour	60004510		UC-L; UC-XL
10				See page 27-28
11				See page 27-28
12	Cylindrical screw; M6 X 20	30000161	3	
13	Intake socket condensation unit; D94 X 127	60004586		
14	Four-lipped seal; D31,34 X 3,53	30000266		
15				See page 27-28
16	Wire hose clamp; D17,3 X 1,8	28 02 353		

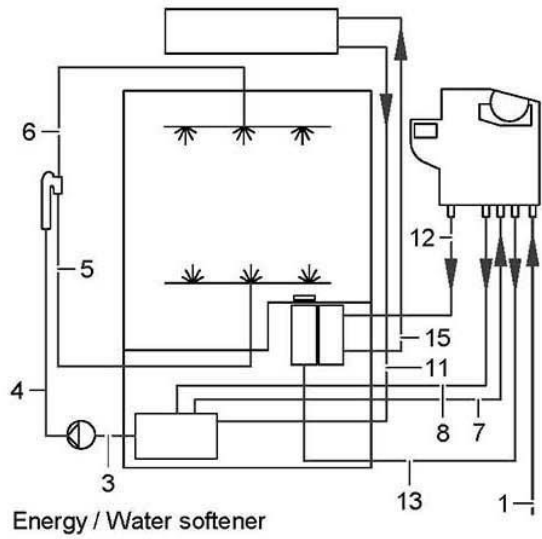
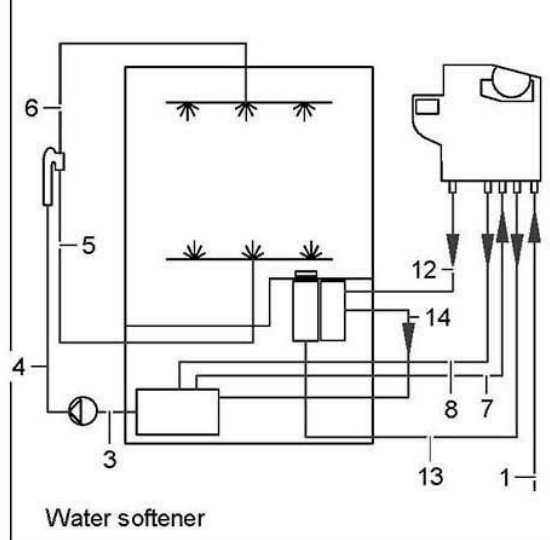
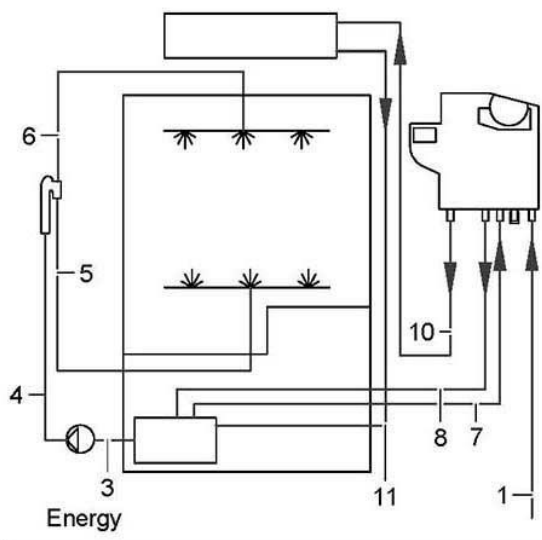
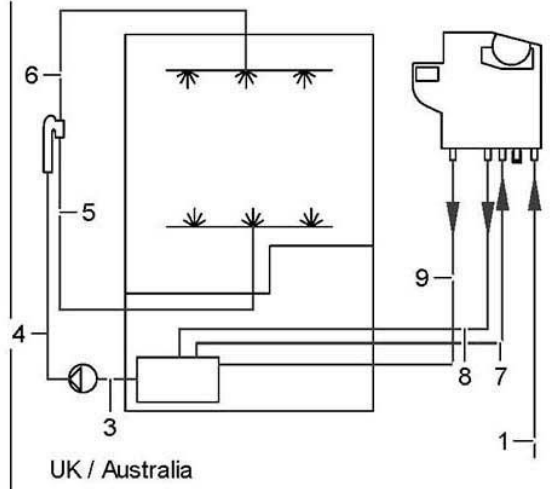
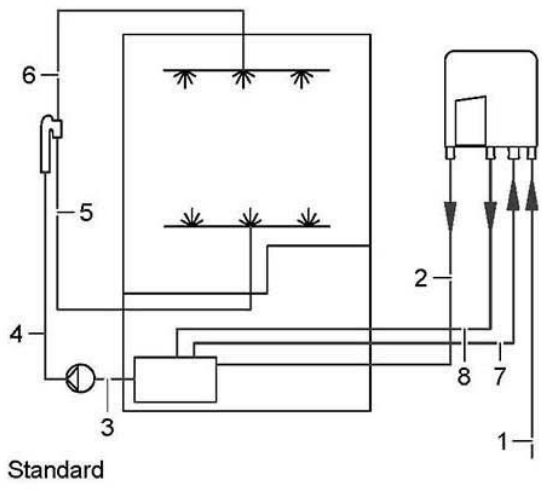

60005017-00

UC-M, UC-L, UC-XL

Hoses

Item.	Designation	Parts no.:	Pc.	Notes
1	Moulded hose; DN10 X 3,5 X 461	60004642		
2	Moulded hose; DN10 X DN11 X 2,0	60004643		
3	Moulded hose; DN23,5 X DN26,5 X 3,5	60004573		
4	Moulded hose; DN18 X DN24 X 3,5	60004632		
5	Moulded hose bottom; DN13,5 X 3,0 X 370	60004625		
6	Moulded hose top; DN13,5 X 3,0 X 605	60004644		UC-M
6	Moulded hose top; DN13,5 X 3,0 X 700	60004624		UC-L; UC-XL
7	Moulded hose; DN13 X 2,0	60004667		
8	Moulded hose; DN10 X DN13 X 2,0	60004664		
9	Moulded hose; DN10 X DN11 X 2,0	60004670		
10	Moulded hose; DN10 X 2,0	60004684		UC-M
10	Moulded hose; DN10 X 2,0	60004673		UC-L; UC-XL
11	Moulded hose; DN13 X 2,0	60004681		UC-M
11	Moulded hose; DN13 X 2,0	60004668		UC-L; UC-XL
12	Hose; DN10 X 2,0	40 01 050		650 mm; "By-the-metre" goods
13	Hose; DN10 X 2,0	40 01 050		800 mm; "By-the-metre" goods
14	Moulded hose; DN10 X DN11 X 2,0	60004671		
15	Moulded hose; DN10 X 2,0	60004683		UC-M
15	Moulded hose; DN10 X 2,0	60004672		UC-L; UC-XL

UC-M, UC-L, UC-XL

Accessories

Item.	Designation	Parts no.:	Pc.	Notes
1	Drip tray; 19,66 X 594 X 604	60004739		
2	Set of vapour protectors, cpl.	80002870		UC-M
3	Set of vapour protectors, cpl.	80002865		UC-L; UC-XL
4	Plinth, movable; 35MM HOCH	75000507		Height: 35 mm
5	Plinth, open; 250MM HOCH	75000350		Height: 250 mm
6	Plinth, open; 400MM HOCH	75000369		Height: 400 mm
7	Plinth, open, movable; 250MM HOCH	75000368		Height: 250 mm
8	Plinth, open, movable; 535MM HOCH	75000374		Height: 535 mm
9	Plinth, closed; 50MM HOCH; 600 BREIT	75000385		Height: 50 mm
10	Plinth, closed; 85MM HOCH; 600 BREIT	75000391		Height: 85 mm
11	Plinth, closed; 135MM HOCH; 600MM BREIT	75000394		Height: 135 mm
12	Fixing foot; D90; M8 X 127,5	80002863		4 pieces required per machine
13	Suction tube SD 425 kit for detergent	30000010		
14	Suction tube SD 425 kit for rinse aid	30000011		
15	Dosing tube connection kit (5 pc.)	30000012		
16	Supply cable, 3-wire; 3 X 2,5QMM; 3000 LG	31 23 125		
17	Supply cable, 5-wire; 5 X 2,5QMM; 3000 LG	31 23 132		